

High Speed Low Dropout Middle Current Voltage Regulators

■ General Description

The LN1134 series are highly precise, positive voltage LDO regulators manufactured using CMOS processes. The series achieves high ripple rejection and low dropout and consists of a standard voltage source, an error amplifier, current limiter and a phase compensation circuit plus a driver transistor. Output voltage is selectable in 100mV increments within a range of 1.5V ~ 5.0V. The series is also compatible with low ESR ceramic capacitors which give added output stability. This stability can be maintained even during load fluctuations due to the excellent transient response of the series.

The current limiter's feedback circuit also operates as a short protect for the output current limiter and the output pin. The CE function enables the output to be turned off, resulting in greatly reduced power consumption.

■ Package

- SOT23-5L
- DFN1010-4L
- SOT353
- SOT343

■ Features

- Output Voltage Range: 1.0V to 5.0V (selectable in 100mV steps)
- Highly Accurate: $\pm 2\%$
- Dropout Voltage: 180mV @ 100mA (3.0V type)
- High Ripple Rejection: 60dB (1 kHz)
- Low Power Consumption: 70 μ A (TYP.)
- Maximum Output Current : 300mA
- Standby Current : less than 0.1 μ A
- Internal protector: current limiter
- Internal discharge MOS

■ Applications

- Mobile phones
- Cordless phones
- Cameras, Video cameras
- Portable games
- Portable AV equipment
- Reference voltage
- Battery powered equipment

■ Typical Application Circuit

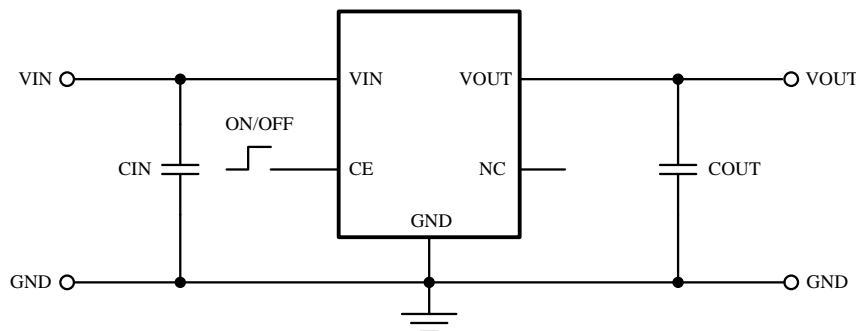

- Caution:**
1. The above connection diagram and constant will not guarantee successful operation. Perform thorough evaluation using the actual application to set the constant.
 2. Input capacitor (CIN): 1.0 μ F or more, Output capacitor (COUT): 1.0 μ F or more
 3. A general series regulator may oscillate, depending on the external components selected. Check that no oscillation occurs with the application using the above capacitor.

Ordering Information

LN1134 ①②③④⑤⑥⑦

Designator	Symbol	Description	Designator	Symbol	Description
①		CE Pin Logic :	⑤		Package Type :
	A	Active 'High' (pull-down resistor built in)		M	SOT23-5L
	B	Active 'High' (no pull-down resistor built in)		K	SOT353
	C	Active 'Low' (pull-up resistor built in)		C	SOT343
	D	Active 'Low' (no pull-up resistor built in)		D	DFN1010-4L
②③	10-60	Output Voltage: e.g. 20 = 2.0V, 30 = 3.0Vetc.	⑥	Device Orientation :	
④	2	Output Voltage : 100mV increments e.g. ②=3, ③=8, ④=2 represents 3.8V		R	Standard Feed
	A	Output Voltage : 50mV increments e.g. ②=3, ③=8, ④=A represents 3.85V		L	Reverse Feed
			⑦	G	Green epoxy molding compound

Pin Configuration

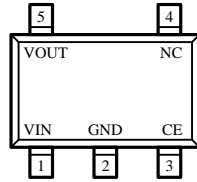
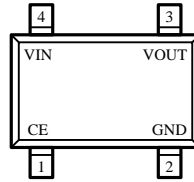
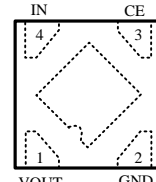

 SOT23-5L/SOT353
 (TOP VIEW)

 SOT343
 (TOP VIEW)

 DFN1010-4L
 (TOP VIEW)

Pin Assignment

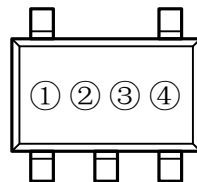
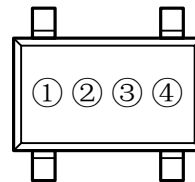
Pin Number			Pin Name	Function
SOT23-5L /SOT353	DFN1010-4L	SOT343		
1	4	4	VIN	Supply power
2	2	2	GND	Ground
3	3	1	CE	Enable pin
4	-	-	NC	NC
5	1	3	VOUT	Voltage output

Marking Rule

- SOT23-5L, SOT353, SOT343

 SOT23-5L/SOT353
 (TOP VIEW)

 SOT343
 (TOP VIEW)

① Represents the product name

Symbol	Product Name
4	LN1134◆◆◆◆◆◆◆◆

② Represents the type of regulator

Voltage(V)	1.0~3.0	3.1~6.0	1.05~3.05	3.15~6.05	Product Name
Symbol	V	A	E	L	LN1134A◆◆◆◆◆◆◆◆
	X	B	F	M	LN1134B◆◆◆◆◆◆◆◆
	Y	C	H	N	LN1134C◆◆◆◆◆◆◆◆
	Z	D	K	P	LN1134D◆◆◆◆◆◆◆◆

③ Represents the Output Voltage

Symbol	Output Voltage(V)			
0	-	3.1	-	3.15
1	-	3.2	-	3.25
2	-	3.3	-	3.35
3	-	3.4	-	3.45
4	-	3.5	-	3.55
5	-	3.6	-	3.65
6	-	3.7	-	3.75
7	-	3.8	-	3.85
8	-	3.9	-	3.95
9	1.0	4.0	1.05	4.05
A	1.1	4.1	1.15	4.15
B	1.2	4.2	1.25	4.25
C	1.3	4.3	1.35	4.35
D	1.4	4.4	1.45	4.45
E	1.5	4.5	1.55	4.55

Symbol	Output Voltage(V)			
F	1.6	4.6	1.65	4.65
H	1.7	4.7	1.75	4.75
K	1.8	4.8	1.85	4.85
L	1.9	4.9	1.95	4.95
M	2.0	5.0	2.05	5.05
N	2.1	-	2.15	-
P	2.2	-	2.25	-
R	2.3	-	2.35	-
S	2.4	-	2.45	-
T	2.5	-	2.55	-
U	2.6	-	2.65	-
V	2.7	-	2.75	-
X	2.8	-	2.85	-
Y	2.9	-	2.95	-
Z	3.0	-	3.05	-

④ Represents the assembly lot no.

0~9, A~Z repeated (G, I, J, O, Q, W excepted)

- DFN1010-4L

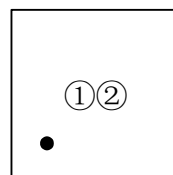

① Represents the Output Voltage

Symbol	Voltage(V)	Symbol	Voltage(V)	Symbol	Voltage(V)	Symbol	Voltage(V)
A	1.1	K	2.1	U	3.1	5	4.1
B	1.2	L	2.2	V	3.2	6	4.2
C	1.3	M	2.3	W	3.3	7	4.3
D	1.4	N	2.4	X	3.4	8	4.4
E	1.5	O	2.5	Y	3.5	9	4.5
F	1.6	P	2.6	Z	3.6	+	4.6
G	1.7	Q	2.7	1	3.7	-	4.7
H	1.8	R	2.8	2	3.8	*	4.8
I	1.9	S	2.9	3	3.9	?	4.9
J	2.0	T	3.0	4	4.0	=	5.0

② Represents the assembly lot No.

0~9, A~Z repeated (G, I, J, O, Q, W excepted)

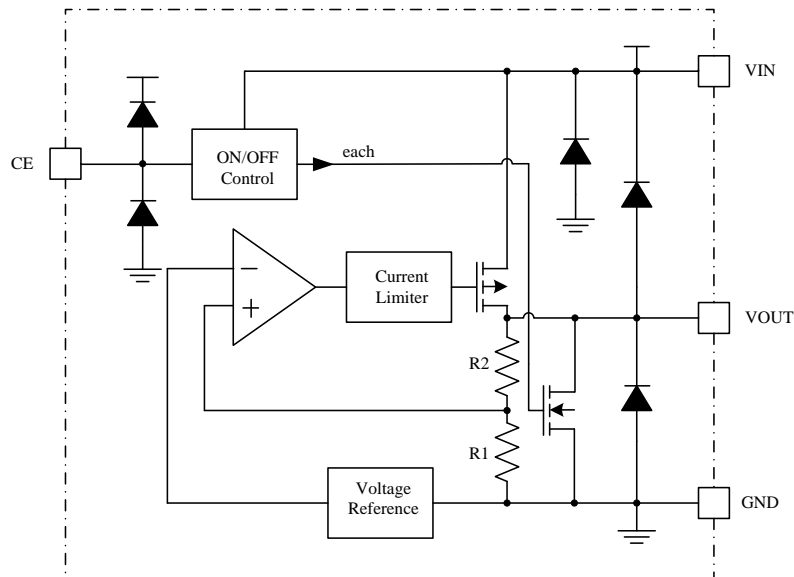
■ Function Block Diagram

■ Absolute Maximum Ratings

Parameter	Symbol	Maximum Rating		Unit
Input Voltage	V_{IN}	-0.3~+8		V
	V_{CE}	-0.3~ $V_{IN}+0.3$		
Output Voltage	V_{OUT}	-0.3~ $V_{IN}+0.3$		
Power Dissipation	P_D	SOT23-5L	400	mW
		SOT353,SOT343	250	
		DFN1010-4L	100	
Operating Ambient Temperature	T_{opr}	-40~+85		°C
Storage Temperature	T_{stg}	-40~+125		

Caution: The absolute maximum ratings are rated values exceeding which the product could suffer physical damage. These values must therefore not be exceeded under any conditions.

■ Electrical Characteristics

(TA=25°C unless otherwise noted)

Parameter	Symbol	Condition	Min	Typ	Max	Unit
Output Voltage	$V_{OUT(E)}$	$V_{IN} = V_{OUT(S)} + 1.0 \text{ V}$, $I_{OUT} = 30 \text{ mA}$	$V_{OUT(S)} \times 0.98$	$V_{OUT(S)}$	$V_{OUT(S)} \times 1.02$	V
Output Current	I_{OUT}	$V_{IN} \geq V_{OUT(S)} + 1.0 \text{ V}$	300	-	-	mA
Dropout Voltage	V_{drop}	$I_{OUT} = 50 \text{ mA}$	-	0.1	0.20	V
		$I_{OUT} = 100 \text{ mA}$	-	0.18	0.45	
Line Regulations	$\frac{\Delta V_{OUT1}}{\Delta V_{IN} \cdot V_{OUT}}$	$V_{OUT(S)} + 0.5 \text{ V} \leq V_{IN} \leq 7 \text{ V}$ $I_{OUT} = 30 \text{ mA}$	-	0.10	0.2	%/V
Load Regulation	ΔV_{OUT2}	$V_{IN} = V_{OUT(S)} + 1.0 \text{ V}$ $1.0 \text{ mA} \leq I_{OUT} \leq 100 \text{ mA}$	-	50	100	mV
Output Voltage Temperature Characteristics	$\frac{\Delta V_{OUT}}{\Delta T_a \cdot V_{OUT}}$	$V_{IN} = V_{OUT(S)} + 1.0 \text{ V}$, $I_{OUT} = 10 \text{ mA}$ $-40^\circ\text{C} \leq T_a \leq 85^\circ\text{C}$	-	± 100	-	ppm/°C
Supply Current	I_{SS1}	$V_{IN} = V_{OUT(S)} + 1.0 \text{ V}$	-	70	-	μA
Input Voltage	V_{IN}	-	2.0	-	7.0	V
Ripple-Rejection	PSRR	$V_{IN} = V_{OUT(S)} + 1.0 \text{ V}$, $f = 1 \text{ kHz}$ $V_{rip} = 0.5 \text{ V}_{rms}$, $I_{OUT} = 50 \text{ mA}$	-	60	-	dB
Short-circuit Current	I_{short}	$V_{IN} = V_{OUT(S)} + 1.0 \text{ V}$, V_{CE} on $V_{OUT} = \text{gnd}$	-	40	-	mA
CE "High" Voltage	V_{CEH}	-	1.6	-	-	V
CE "Low" Voltage	V_{CEL}	-	-	-	0.8	V
CE "High" Current (no resistor built in)	I_{CEH}	$V_{IN} = V_{CE} = V_{OUT(T)} + 1.0 \text{ V}$	-0.1	-	0.1	uA
CE "Low" Current (no resistor built in)	I_{CEL}	$V_{IN} = V_{OUT(T)} + 1.0 \text{ V}$, $V_{CE} = V_{SS}$	-0.1	-	0.1	uA
Inrush Current	I_{RUSH}	$V_{IN} = V_{OUT(T)} + 1 \text{ V}$, $C_L = 47 \mu\text{F}$, $V_{CE} = 0 \rightarrow V_{OUT(T)} + 1 \text{ V}$ (Only when rising and within 1ms)	-	-	800	mA

Typical Performance Characteristics (3.3V output)

1. Quiescent Current VS Input Voltage

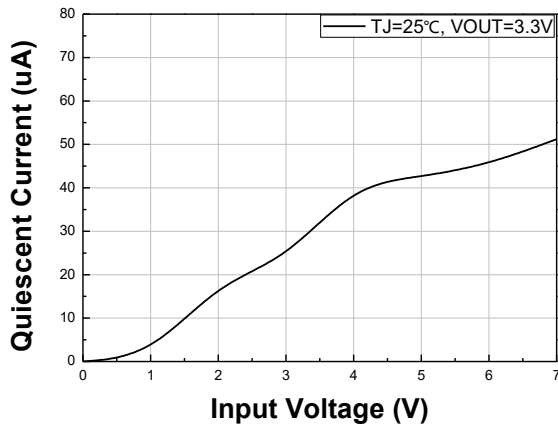

2. Output Voltage VS Input Voltage

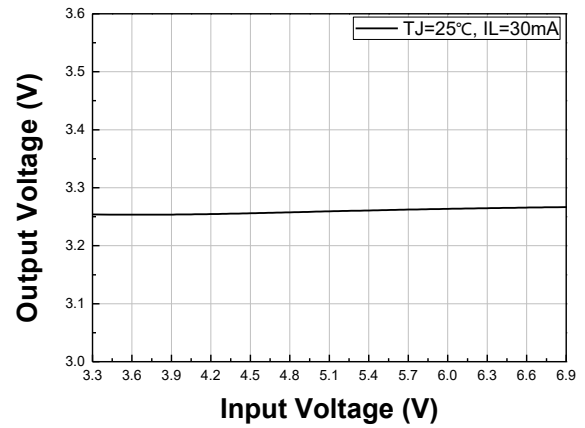

3. Output Current Limit VS Input Voltage

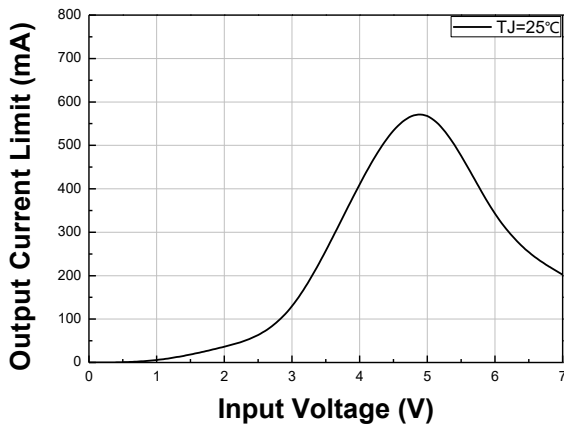

4. GND Pin Current VS Input Voltage

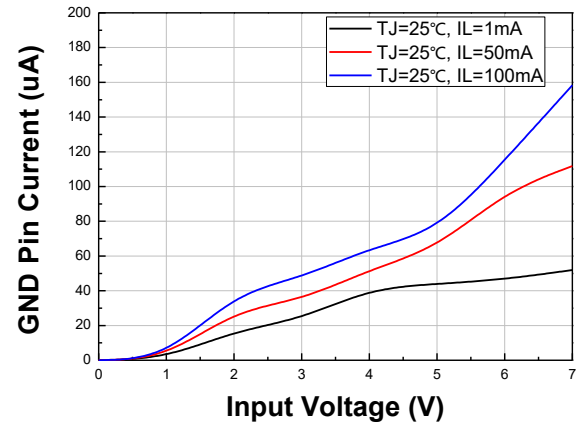

5. GND Pin Current VS Output Current

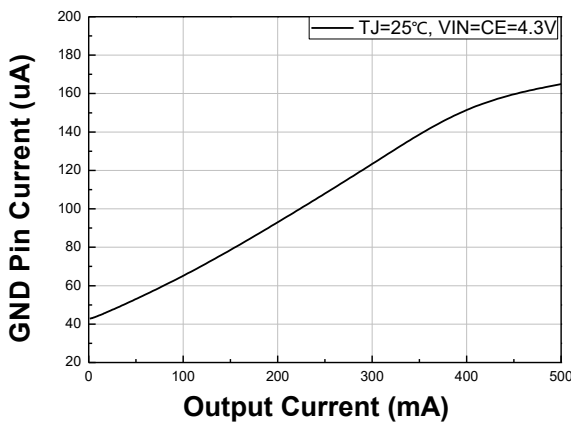

6. Quiescent Current VS Temperature

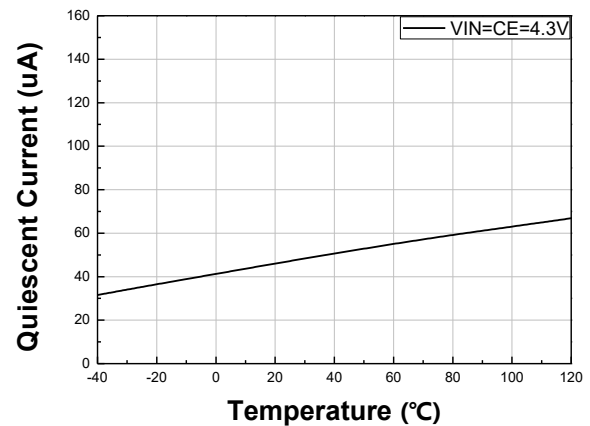

7. Output Current Limit VS Temperature

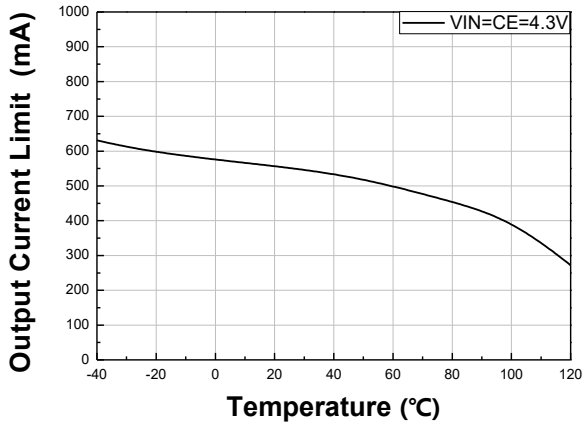

8. Output Voltage VS Temperature

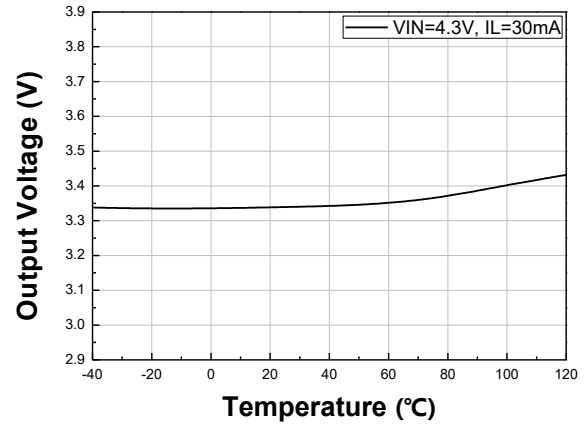

9. Dropout Voltage VS Temperature

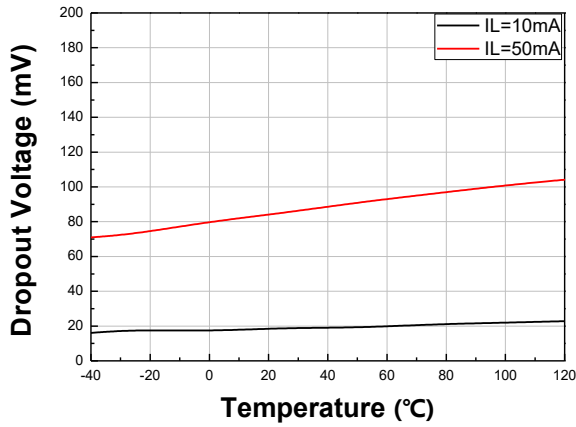

10. CE "High" Voltage VS Temperature

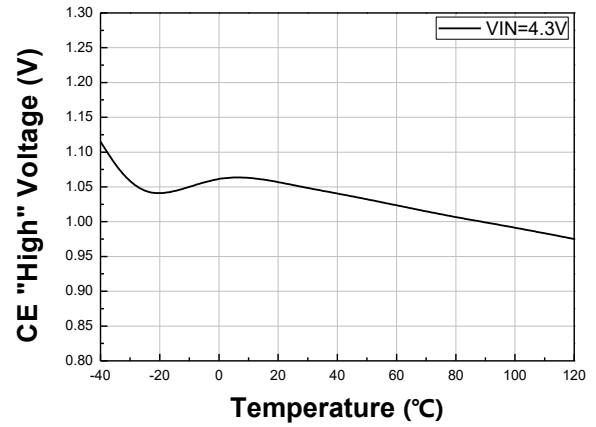

11. CE "Low" Voltage VS Temperature

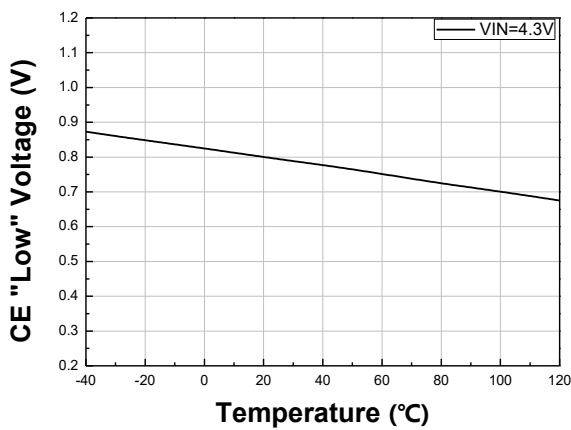

12. Load Regulation VS Temperature

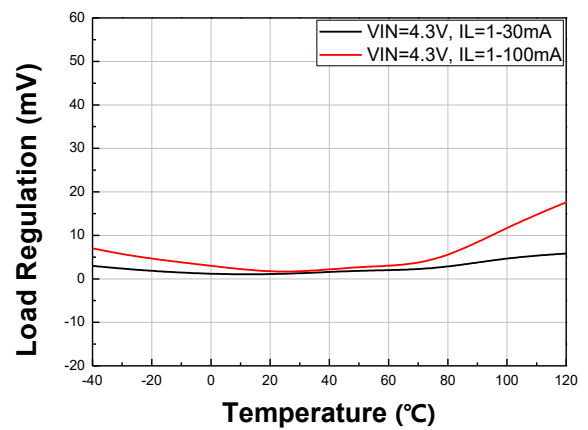

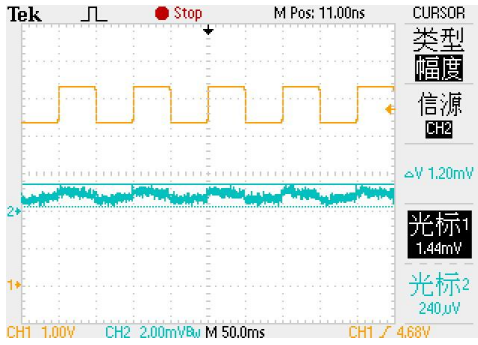
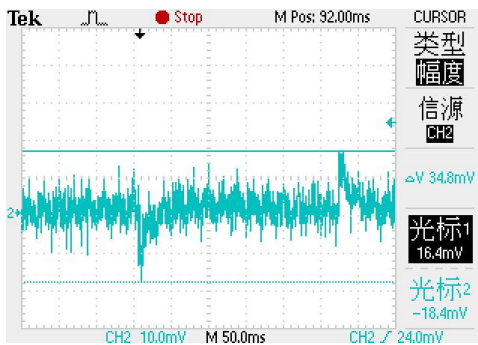
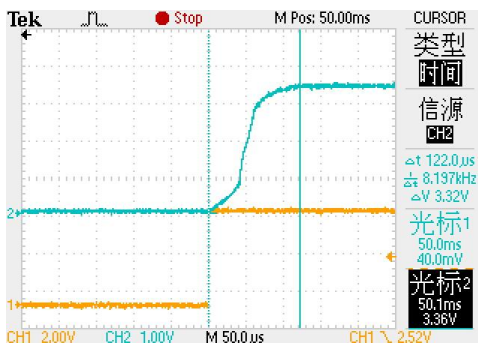
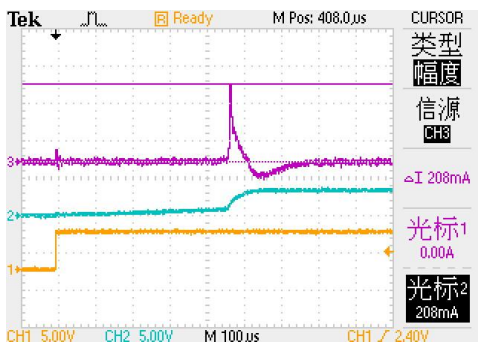
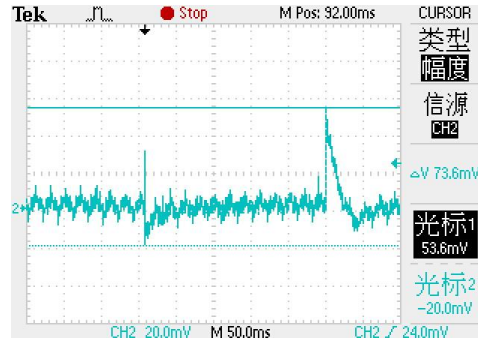
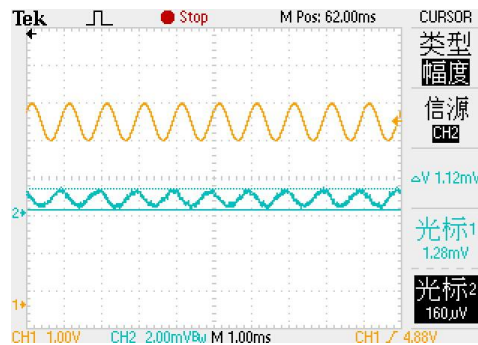
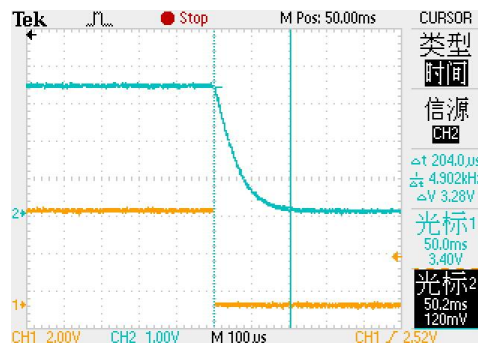
13. Input voltage transient response (IL=30mA)

15. Load transient response (IL=10-350-10mA)

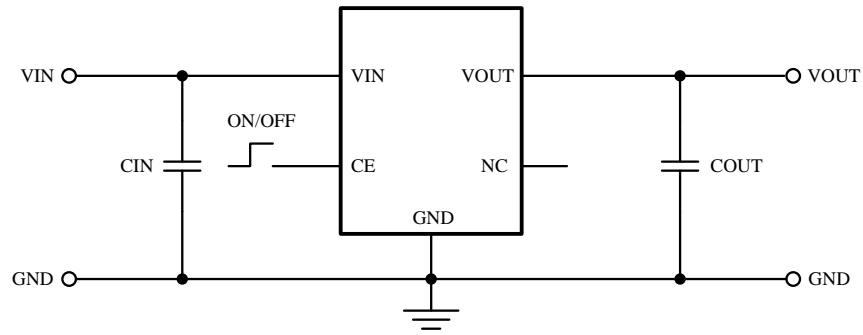
17. CE Opening Time

19. Inrush Current

14. Load transient response (IL=0-350-0mA)

16. Ripple-Rejection (IL=50mA, Vpp=1V, F=1KHZ)

18. CE Turn-off Time

■ Application information



- **Setting the Input Capacitor and the Output Capacitor**

Input capacitors (CIN) and output capacitors(COUT) are recommended to use more than 1uF, which can ensure the stability of the system

- **PCB Layout**

In order to get better use effect, the main points for attention of PCB layout are as follows:

- The input and output capacitors are as close as possible to the chip pins.
- The wiring of VIN and VOUT should be as thick as possible to reduce the wiring resistance and improve the load performance.
- The route from GND(pin) to GND uses a dedicated channel to prevent parasitic resistance from introducing into the change path, which results in incorrect feedback ratio and output error.

Package Information

- SOT23-5L

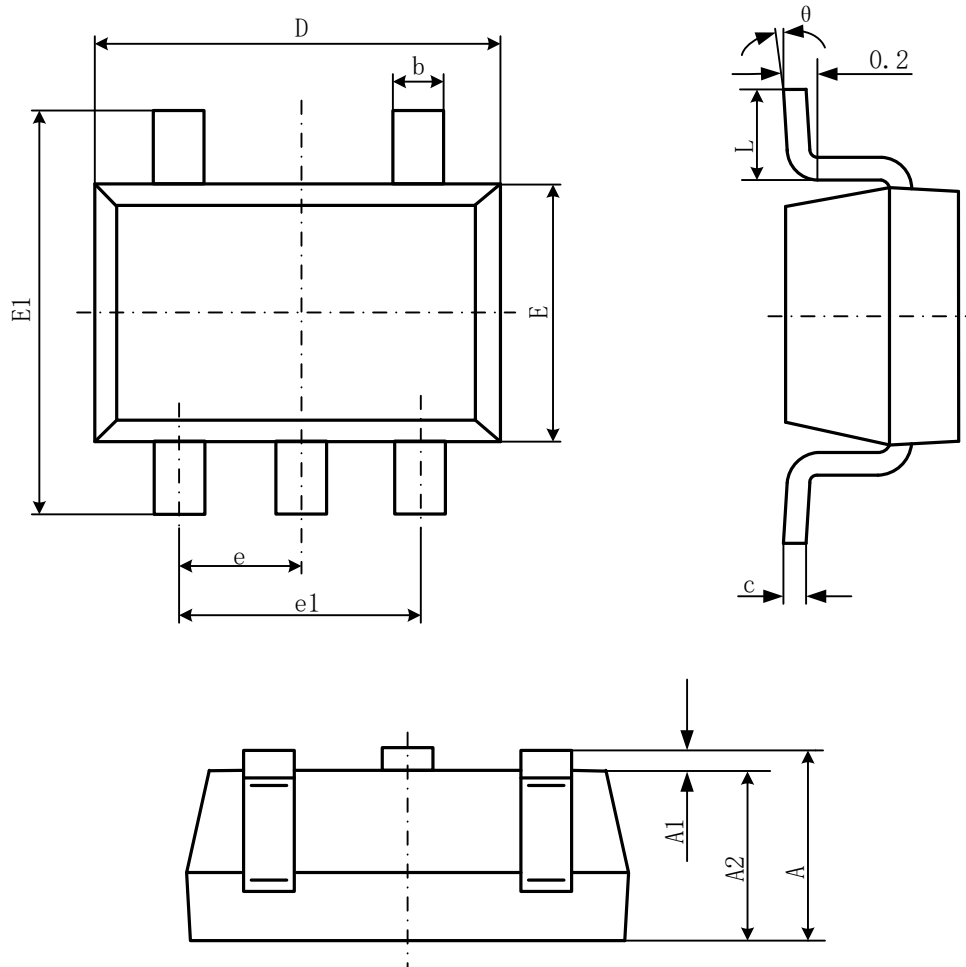

Symbol	Dimensions In Millimeters		Dimensions In Inches	
	Min	Max	Min	Max
A	1.050	1.250	0.041	0.049
A1	0.000	0.100	0.000	0.004
A2	1.050	1.150	0.041	0.045
b	0.300	0.500	0.012	0.020
c	0.100	0.200	0.004	0.008
D	2.820	3.020	0.111	0.119
E	1.500	1.700	0.059	0.067
E1	2.650	2.950	0.104	0.116
e	0.950(BSC)		0.037(BSC)	
e1	1.800	2.000	0.071	0.079
L	0.300	0.600	0.012	0.024
θ	0°	8°	0°	8°

● DFN1010-4L

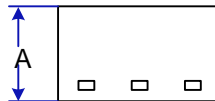
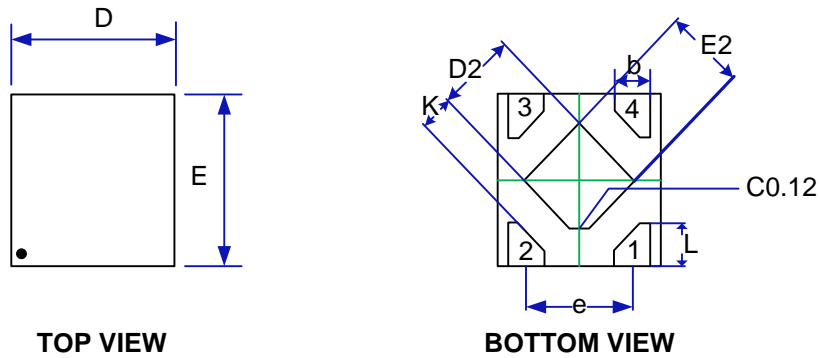
 ● **SIDE VIEW**

Symbol	Dimensions In Millimeters		Dimensions In Inches	
	Min	Max	Min	Max
A	0.34	0.40	0.013	0.016
b	0.17	0.27	0.007	0.011
D	0.95	1.05	0.037	0.041
E	0.95	1.05	0.037	0.041
D2	0.43	0.53	0.017	0.021
E2	0.43	0.53	0.017	0.021
L	0.20	0.30	0.008	0.012
e	0.60	0.70	0.024	0.028
K	0.15	-	0.006	-

● SOT353

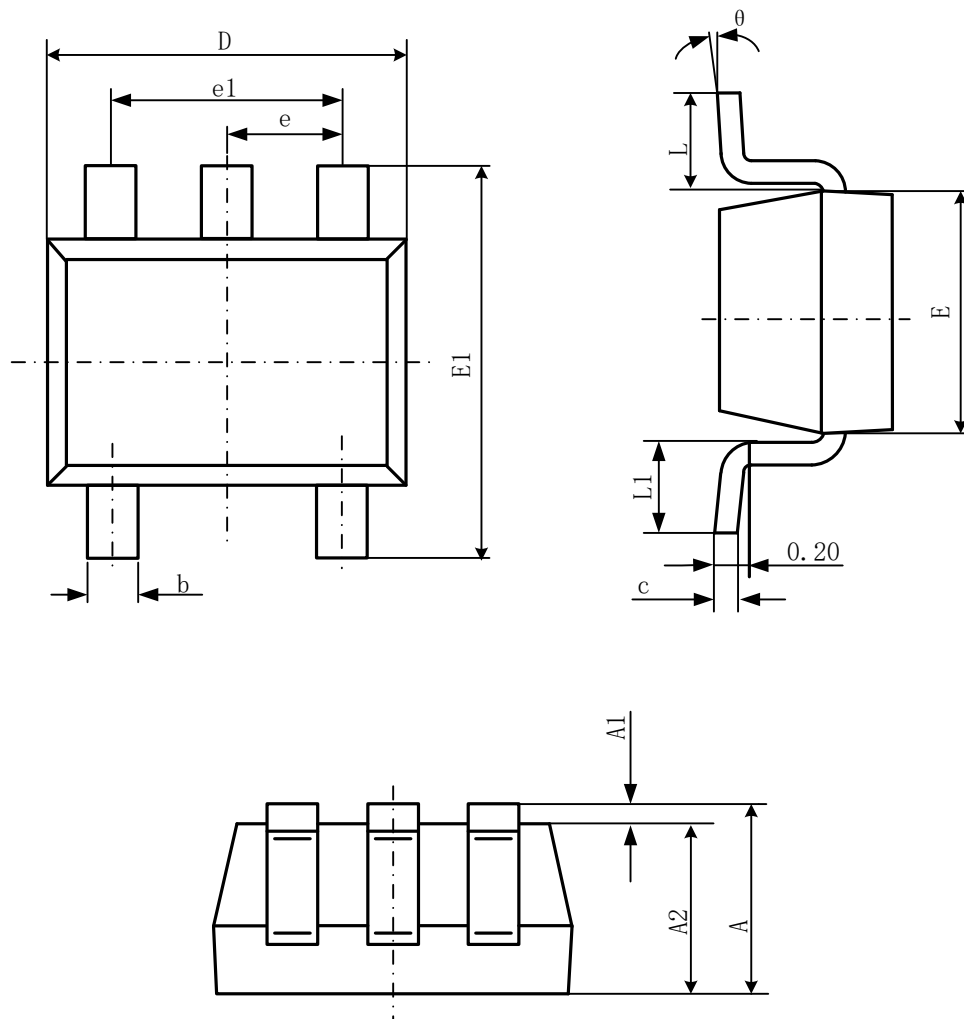

Symbol	Dimensions In Millimeters		Dimensions In Inches	
	Min	Max	Min	Max
A	0.900	1.100	0.035	0.043
A1	0.000	0.100	0.000	0.004
A2	0.900	1.000	0.035	0.039
b	0.150	0.350	0.006	0.014
c	0.080	0.150	0.003	0.006
D	2.000	2.200	0.079	0.087
E	1.150	1.350	0.045	0.053
E1	2.150	2.450	0.085	0.096
e	0.650TYP		0.026TYP	
e1	1.200	1.400	0.047	0.055
L	0.525REF		0.021REF	
L1	0.260	0.460	0.010	0.018
θ	0°	8°	0°	8°

● SOT343

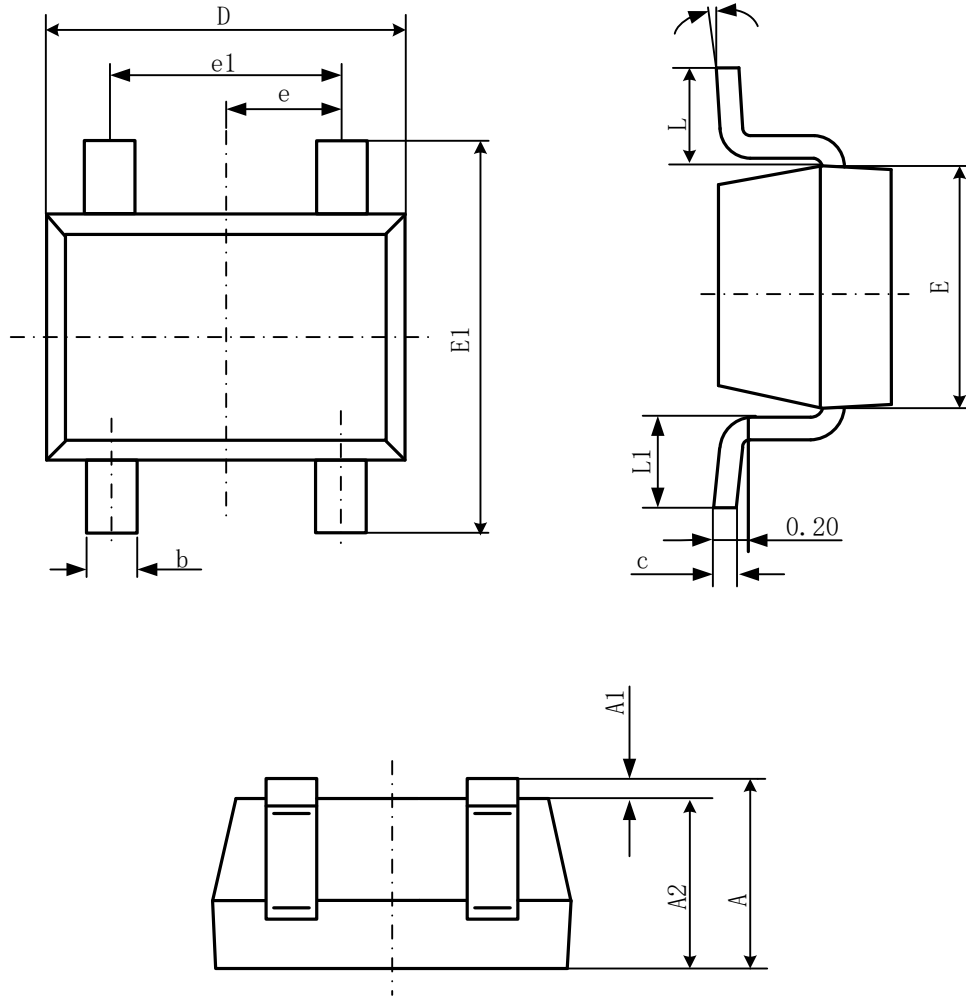

Symbol	Dimensions In Millimeters		Dimensions In Inches	
	Min	Max	Min	Max
A	0.900	1.100	0.035	0.043
A1	0.000	0.100	0.000	0.004
A2	0.900	1.000	0.035	0.039
b	0.150	0.350	0.006	0.014
c	0.080	0.150	0.003	0.006
D	2.000	2.200	0.079	0.087
E	1.150	1.350	0.045	0.053
E1	2.150	2.450	0.085	0.096
e	0.650TYP		0.026TYP	
e1	1.200	1.400	0.047	0.055
L	0.525REF		0.021REF	
L1	0.260	0.460	0.010	0.018
θ	0°	8°	0°	8°