

FAIRCHILD

A Schlumberger Company

μ A78H05 • μ A78H05A 5-Volt 5-Amp Voltage Regulators

Hybrid Products

Description

The μ A78H05 and μ A78H05A are hybrid regulators with 5.0 V fixed outputs and 5.0 A output capabilities. They have the inherent characteristics of the monolithic 3-terminal regulators, i.e., full thermal overload, short-circuit and safe-area protection. All devices are packaged in hermetically sealed TO-3s providing 50 W power dissipation. If the safe operating area is exceeded, the device shuts down rather than failing or damaging other system components (Note 1). This feature eliminates costly output circuitry and overly conservative heat sinks typical of high-current regulators built from discrete components.

- 5.0 A OUTPUT CURRENT
- INTERNAL CURRENT AND THERMAL OVERLOAD PROTECTION
- INTERNAL SHORT CIRCUIT PROTECTION
- LOW DROPOUT VOLTAGE (TYPICALLY 2.3 V @ 5.0 A)
- 50 W POWER DISSIPATION
- STEEL TO-3 PACKAGE
- ALL PIN-FOR-PIN COMPATIBLE WITH THE SH323

Note

1. These voltage regulators offer output transistor safe-area protection. However, to maintain full protection, the devices must be operated within the maximum input-to-output voltage differential ratings, as listed on this data sheet under "Absolute Maximum Ratings." For applications violating these limits, devices will not be fully protected.

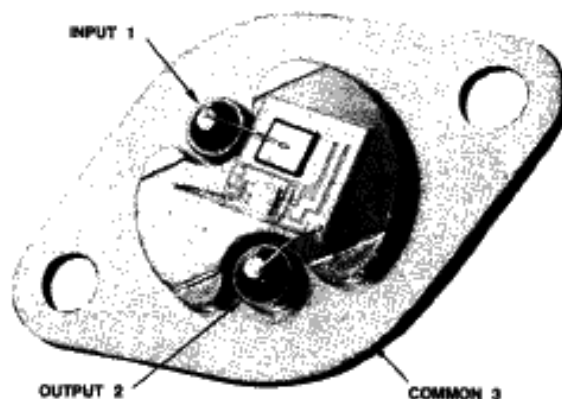
**Connection Diagram
TO-3 Metal Package**

(Top View)

Order Information

Type	Package	Code	Part No.
μ A7805	Metal	GN	μ A78H05SC
μ A7805A	Metal	GN	μ A78H05ASC
μ A7805	Metal	GN	μ A78H05SM
μ A7805A	Metal	GN	μ A78H05ASM

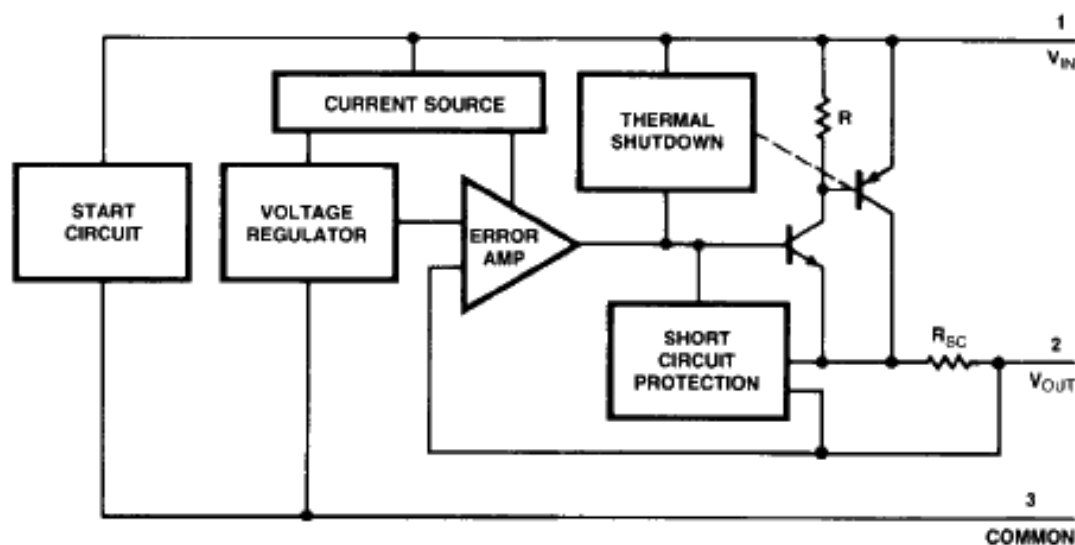
Block Diagram

μA78H05 • μA78H05A

Absolute Maximum Ratings

Input Voltage	40 V	Commercial Temperature Range	
Input-to-Output Voltage Differential, Output Short Circuited	35 V	μA78H05SC	0°C to +150°C
Internal Power Dissipation	50 W @ 25°C Case	μA78H05ASC	0°C to +150°C
Operating Junction Temperature	150°C	Storage Temperature Range	-55°C to +150°C
Military Temperature Range		Pin Temperature (Soldering, 60 s)	300°C
μA78H05SM	-55°C to +150°C		
μA78H05ASM	-55°C to +150°C		

μA78H05 • μA78H05A

Electrical Characteristics $T_J = 25^\circ\text{C}$, $V_{IN} = 10\text{ V}$, $I_{OUT} = 2.0\text{ A}$ unless otherwise specified.

Symbol	Characteristic	Condition	Limits			Unit
			Min	Typ	Max	
V_{OUT}	Output Voltage	$I_{OUT} = 2.0\text{ A}$	4.85	5.0	5.25	V
ΔV_{OUT}	Line Regulation (Note 2)	$V_{IN} = 8.5\text{ to }25\text{ V}$ (μA78H05)		10	50	mV
		$V_{IN} = 7.5\text{ to }25\text{ V}$ (μA78H05A)		10	50	mV
ΔV_{OUT}	Load Regulation (Note 2)	$10\text{ mA} \leq I_{OUT} \leq 5.0\text{ A}$		10	50	mV
I_Q	Quiescent Current	$I_{OUT} = 0$		3.0	10	mA
RR	Ripple Rejection	$I_{OUT} = 1.0\text{ A}$, $f = 120\text{ Hz}$, 5.0 V_{pk-pk}	60			dB
V_n	Output Noise	$10\text{ Hz} \leq f \leq 100\text{ kHz}$		40		μV _{RMS}
V_{DD}	Dropout Voltage (Note 3)	μA78H05	$I_{OUT} = 5.0\text{ A}$	2.3		V
			$I_{OUT} = 3.0\text{ A}$	2.0		V
		μA78H05A	$I_{OUT} = 5.0\text{ A}$	2.3	2.5	V
			$I_{OUT} = 3.0\text{ A}$	2.0	2.3	V
I_{OS}	Short-Circuit Current Limit		7.0	12.0	A _{pk}	

Notes

- Load and line regulation are specified at constant junction temperature. Pulse testing is required with a pulse width $\leq 1\text{ ms}$ and a duty cycle of $\leq 5\%$. Full Kelvin connection methods must be used to measure these parameters.
- Dropout Voltage is the input-output voltage differential that causes the output voltage to decrease by 5% of its initial value.

Typical Performance Curves

Output Impedance

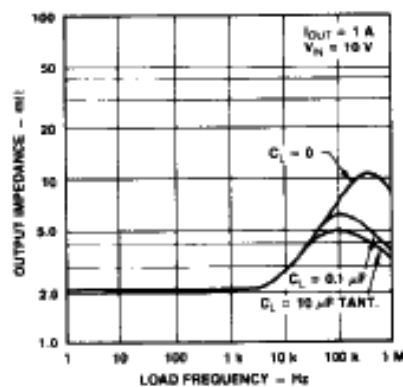

Output Noise Voltage

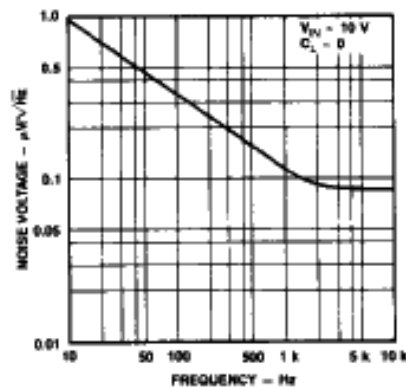

Maximum Power Dissipation

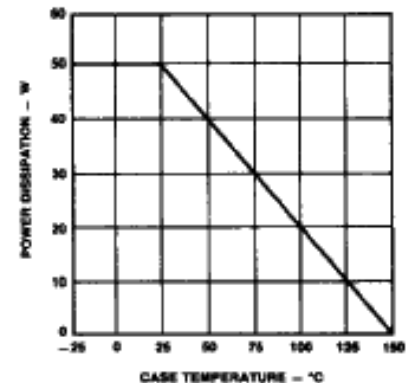

Typical Performance Curves (Cont.)

Short Circuit Current

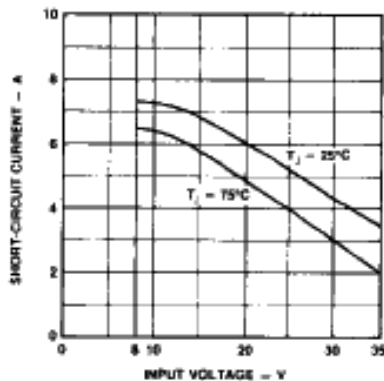

Quiescent Current

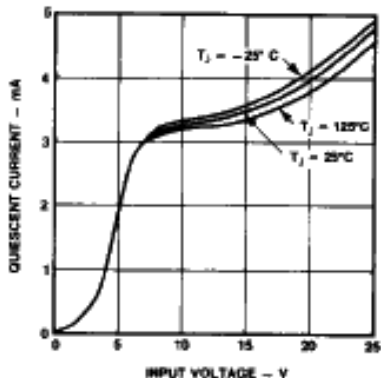

Dropout Voltage

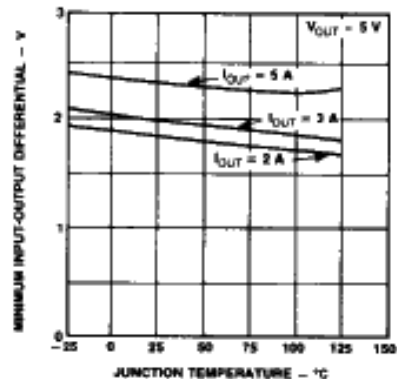

Line Regulation

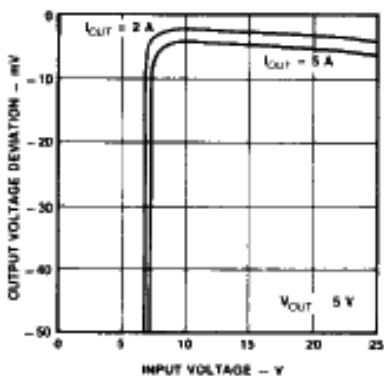

Line Transient Response

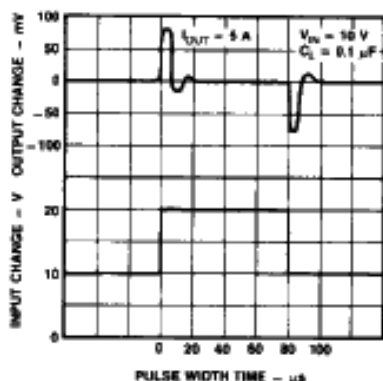

Ripple Rejection

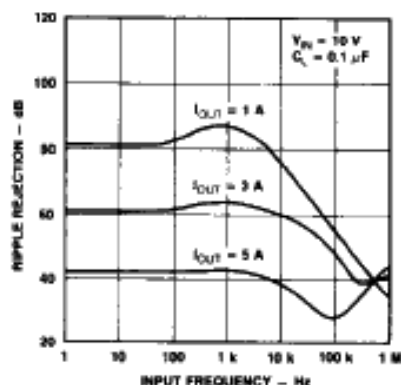

Load Regulation

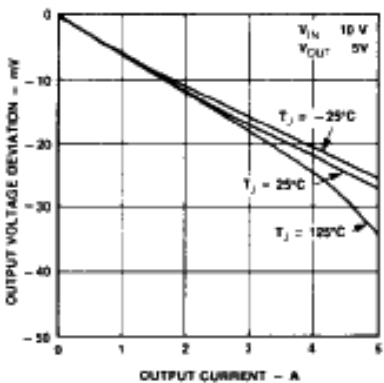

Load Transient Response

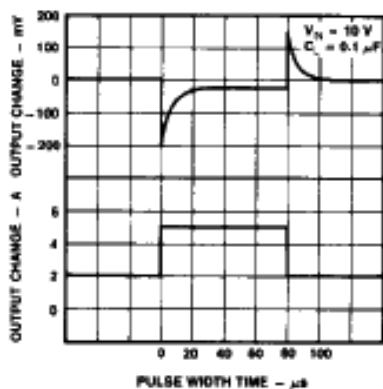

Output Voltage Deviation vs Junction Temperature

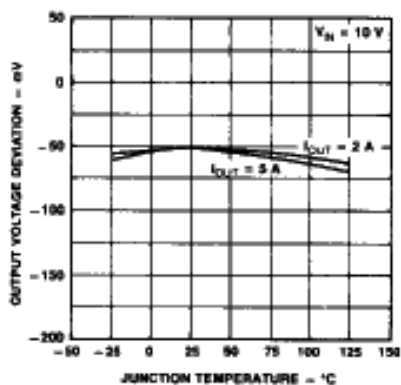

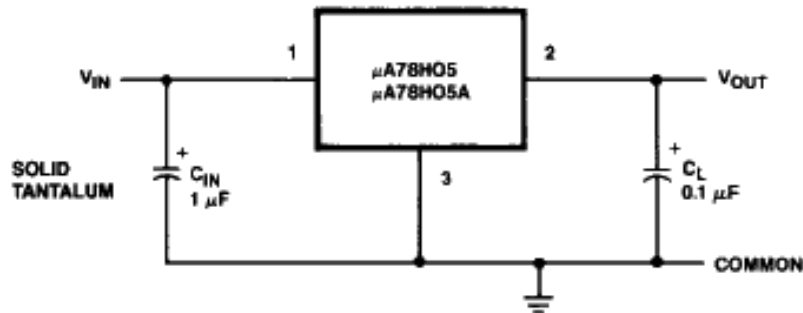
Test Circuit**Fixed Output Voltage****Design Considerations**

These devices have thermal-overload protection from excessive power and internal short-circuit protection which limits the circuit's maximum current. Thus, the devices are protected from overload abnormalities. Although the internal power dissipation is limited, the junction temperature must be kept below the maximum specified temperature (150°C). It is recommended by the manufacturer that the maximum junction temperature be kept as low as possible for increased reliability. To calculate the maximum junction temperature or heat sink required, the following thermal resistance values should be used:

Package	Typ θ_{JC}	Max θ_{JC}
TO-3	1.8	2.5

$$P_{D(\max)} = \frac{T_{J(\max)} - T_A}{\theta_{JC} + \theta_{CA}}$$

$$\theta_{CA} = \theta_{CS} + \theta_{SA}$$

Solving for T_J :

$$T_J = T_A + P_D (\theta_{JC} + \theta_{CA})$$

Where:

- T_J = Junction Temperature
- T_A = Ambient Temperature
- P_D = Power Dissipation
- θ_{JC} = Junction-to-case thermal resistance
- θ_{CA} = Case-to-ambient thermal resistance
- θ_{CS} = Case-to-heat sink thermal resistance
- θ_{SA} = Heat sink-to-ambient thermal resistance

The devices are designed to operate without external compensation components. However, the amount of external filtering of these voltage regulators depends upon the circuit layout. If in a specific application the regulator is more than four inches from the filter capacitor, a 1 μF solid tantalum capacitor should be used at the input. A 0.1 μF capacitor should be used at the output to reduce transients created by fast switching loads, as seen in the basic test circuit. These filter capacitors must be located as close to the regulator as possible.

Caution: Permanent damage can result from forcing the output voltage higher than the input voltage. A protection diode from output to input should be used if this condition exists.