

FEATURES

- Two Precision Timing Circuits Per Package
- Astable or Monostable Operation
- TTL-Compatible Output Can Sink or Source up to 150 mA
- Active Pullup or Pulldown
- Designed to Be Interchangeable With Signetics NE556, SA556, and SE556

APPLICATIONS

- Precision Timers From Microseconds to Hours
- Pulse-Shaping Circuits
- Missing-Pulse Detectors
- Tone-Burst Generators
- Pulse-Width Modulators
- Pulse-Position Modulators
- Sequential Timers
- Pulse Generators
- Frequency Dividers
- Application Timers
- Industrial Controls
- Touch-Tone Encoders

DESCRIPTION/ORDERING INFORMATION

These devices provide two independent timing circuits of the NA555, NE555, SA555, or SE555 type in each package. These circuits can be operated in the astable or the monostable mode with external resistor-capacitor (RC) timing control. The basic timing provided by the RC time constant can be controlled actively by modulating the bias of the control-voltage input.

The threshold (THRES) and trigger (TRIG) levels normally are two-thirds and one-third, respectively, of V_{CC} . These levels can be altered by using the control voltage (CONT) terminal. When the trigger input falls below trigger level, the flip-flop is set and the output goes high. If the trigger input is above the trigger level and the threshold input is above the threshold level, the flip-flop is reset, and the output is low. The reset (RESET) input can override all other inputs and can be used to initiate a new timing cycle. When RESET goes low, the flip-flop is reset and the output goes low. When the output is low, a low-impedance path is provided between the discharge (DISCH) terminal and ground (GND).

NA556...D OR N PACKAGE
NE556...D, N, OR NS PACKAGE
SA556...D OR N PACKAGE
SE556...J PACKAGE
(TOP VIEW)



Please be aware that an important notice concerning availability, standard warranty, and use in critical applications of Texas Instruments semiconductor products and disclaimers thereto appears at the end of this data sheet.

ORDERING INFORMATION

T _A	V _T (MAX) V _{CC} = 15 V	PACKAGE ⁽¹⁾		ORDERABLE PART NUMBER	TOP-SIDE MARKING
0°C to 70°C	11.2 V	PDIP – N	Tube of 25	NE556N	NE556N
		SOIC – D	Tube of 50	NE556D	NE556
			Reel of 2500	NE556DR	
		SOP – NS	Reel of 2000	NE556NSR	NE556
–40°C to 85°C	11.2 V	PDIP – N	Tube of 25	SA556N	SA556N
–40°C to 105°C	11.2 V	PDIP – N	Tube of 25	NA556N	NA556N
		SOIC – D	Tube of 50	NA556D	NA556
			Reel of 2500	NA556DR	
–55°C to 125°C	10.6 V	CDIP – J	Tube of 25	SE556J	SE556J
				SE556JB	SE556JB

(1) Package drawings, standard packing quantities, thermal data, symbolization, and PCB design guidelines are available at www.ti.com/sc/package.

FUNCTION TABLE
 (each timer)

RESET	TRIGGER VOLTAGE ⁽¹⁾	THRESHOLD VOLTAGE ⁽¹⁾	OUTPUT	DISCHARGE SWITCH
Low	Irrelevant	Irrelevant	Low	On
High	<1/3 V _{DD}	Irrelevant	High	Off
High	>1/3 V _{DD}	>2/3 V _{DD}	Low	On
High	>1/3 V _{DD}	<2/3 V _{DD}	As previously established	

(1) Voltage levels shown are nominal.

FUNCTIONAL BLOCK DIAGRAM, EACH TIMER

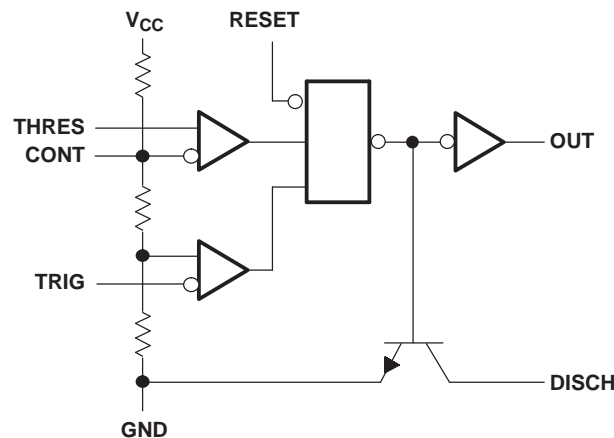

RESET can override TRIG, which can override THRES.

Absolute Maximum Ratings⁽¹⁾

over operating free-air temperature range (unless otherwise noted)

		MIN	MAX	UNIT
V _{CC}	Supply voltage ⁽²⁾		18	V
V _I	Input voltage	CONT, RESET, THRES, and TRIG		V _{CC}
I _O	Output current		±225	mA
θ _{JA}	Package thermal impedance ⁽³⁾⁽⁴⁾	D package		86
		N package		80
		NS package		76
θ _{JC}	Package thermal impedance ⁽⁵⁾⁽⁶⁾	J package		15.05
T _J	Operating virtual junction temperature		150	°C
	Lead temperature 1,6 mm (1/16 in) from case for 60 s	J package		300
	Lead temperature 1,6 mm (1/16 in) from case for 10 s	D, N, or NS package		260
T _{stg}	Storage temperature range	–65	150	°C

- (1) Stresses beyond those listed under "absolute maximum ratings" may cause permanent damage to the device. These are stress ratings only, and functional operation of the device at these or any other conditions beyond those indicated under "recommended operating conditions" is not implied. Exposure to absolute-maximum-rated conditions for extended periods may affect device reliability.
- (2) All voltage values are with respect to network ground terminal.
- (3) Maximum power dissipation is a function of T_{J(max)}, θ_{JA}, and T_A. The maximum allowable power dissipation at any allowable ambient temperature is P_D = (T_{J(max)} – T_A)/θ_{JA}. Operating at the absolute maximum T_J of 150°C can affect reliability.
- (4) The package thermal impedance is calculated in accordance with JESD 51-7.
- (5) Maximum power dissipation is a function of T_{J(max)}, θ_{JC}, and T_C. The maximum allowable power dissipation at any allowable case temperature is P_D = (T_{J(max)} – T_C)/θ_{JC}. Operating at the absolute maximum T_J of 150°C can affect reliability.
- (6) The package thermal impedance is calculated in accordance with MIL-STD-883.

Recommended Operating Conditions

		MIN	MAX	UNIT
V _{CC}	Supply voltage	NA556, NE556, SA556		V
		SE556		
V _I	Input voltage	CONT, RESET, THRES, and TRIG		V _{CC}
I _O	Output current		±200	mA
T _A	Operating free-air temperature	NA556		°C
		NE556		
		SA556		
		SE556		

Electrical Characteristics

$V_{CC} = 5\text{ V to }15\text{ V}$, $T_A = 25^\circ\text{C}$ (unless otherwise noted)

PARAMETER	TEST CONDITIONS	NA556 NE556 SA556			SE556			UNIT
		MIN	TYP	MAX	MIN	TYP	MAX	
V_T Threshold voltage level	$V_{CC} = 15\text{ V}$	8.8	10	11.2	9.4	10	10.6	V
	$V_{CC} = 5\text{ V}$	2.4	3.3	4.2	2.7	3.3	4	
I_T Threshold current ⁽¹⁾			30	250		30	250	nA
V_{TRIG} Trigger voltage level	$V_{CC} = 15\text{ V}$	4.5	5	5.6	4.8	5	5.2	V
	$T_A = -55^\circ\text{C to }125^\circ\text{C}$				3		6	
V_{TRIG} Trigger voltage level	$V_{CC} = 5\text{ V}$	1.1	1.67	2.2	1.45	1.67	1.9	V
	$T_A = -55^\circ\text{C to }125^\circ\text{C}$						1.9	
I_{TRIG} Trigger current	TRIG at 0 V		0.5	2		0.5	0.9	μA
V_{RESET} Reset voltage level		0.3	0.7	1	0.3	0.7	1	V
	$T_A = -55^\circ\text{C to }125^\circ\text{C}$						1.1	
I_{RESET} Reset current	RESET at V_{CC}		0.1	0.4		0.1	0.4	mA
	RESET at 0 V		-0.4	1.5		-0.4	-1	
I_{DISCH} Discharge switch off-state current			20	100		20	100	nA
V_{CONT} Control voltage (open circuit)	$V_{CC} = 15\text{ V}$	9	10	11	9.6	10	10.4	V
	$T_A = -55^\circ\text{C to }125^\circ\text{C}$				9.6		10.4	
V_{CONT} Control voltage (open circuit)	$V_{CC} = 5\text{ V}$	2.6	3.3	4	2.9	3.3	3.8	V
	$T_A = -55^\circ\text{C to }125^\circ\text{C}$				2.9		3.8	
V_{OL} Low-level output voltage	$V_{CC} = 15\text{ V}$, $I_{OL} = 10\text{ mA}$		0.1	0.25		0.1	0.15	V
	$T_A = -55^\circ\text{C to }125^\circ\text{C}$						0.2	
	$V_{CC} = 15\text{ V}$, $I_{OL} = 50\text{ mA}$		0.4	0.75		0.4	0.5	
	$T_A = -55^\circ\text{C to }125^\circ\text{C}$						1	
	$V_{CC} = 15\text{ V}$, $I_{OL} = 100\text{ mA}$		2	2.5		2	2.2	
	$T_A = -55^\circ\text{C to }125^\circ\text{C}$						2.7	
	$V_{CC} = 15\text{ V}$, $I_{OL} = 200\text{ mA}$		2.5			2.5		
V_{OH} High-level output voltage	$V_{CC} = 15\text{ V}$, $I_{OH} = -100\text{ mA}$	12.75	13.3		13	13.3		V
	$T_A = -55^\circ\text{C to }125^\circ\text{C}$				12			
	$V_{CC} = 15\text{ V}$, $I_{OH} = -200\text{ mA}$		12.5			12.5		
	$V_{CC} = 5\text{ V}$, $I_{OH} = -100\text{ mA}$	2.75	3.3		3	3.3		
	$T_A = -55^\circ\text{C to }125^\circ\text{C}$				2			
	$V_{CC} = 5\text{ V}$, $I_{OL} = 5\text{ mA}$		0.1	0.25		0.1	0.15	
	$T_A = -55^\circ\text{C to }125^\circ\text{C}$						0.8	
I_{CC} Supply current	Output low, No load		20	30		20	24	mA
	$V_{CC} = 15\text{ V}$							
	$V_{CC} = 5\text{ V}$		6	12		6	10	
	$T_A = -55^\circ\text{C to }125^\circ\text{C}$							
Output high, No load	$V_{CC} = 15\text{ V}$		18	26		18	20	
	$V_{CC} = 5\text{ V}$		4	10		4	8	
	$T_A = -55^\circ\text{C to }125^\circ\text{C}$							
	$V_{CC} = 15\text{ V}$							

(1) This parameter influences the maximum value of the timing resistors R and R_B in the circuit of Figure 1. For example, when $V_{CC} = 5\text{ V}$, the maximum value is $R = R_A + R_B \approx 3.4\text{ M}\Omega$, and for $V_{CC} = 15\text{ V}$, the maximum value is $\approx 10\text{ M}\Omega$.

Operating Characteristics

$V_{CC} = 5\text{ V}$ and 15 V

PARAMETER		TEST CONDITIONS ⁽¹⁾	NA556 NE556 SA556			SE556			UNIT
			MIN	TYP	MAX	MIN	TYP	MAX	
Initial error of timing interval ⁽²⁾	Each timer, monostable ⁽³⁾	$T_A = 25^\circ\text{C}$		1	3		0.5	1.5 ⁽⁴⁾	
	Each timer, astable ⁽⁵⁾			2.25%			1.5%		
	Timer 1 – Timer 2			± 1			± 0.5		
Temperature coefficient of timing interval	Each timer, monostable ⁽³⁾	$T_A = \text{MIN to MAX}$		50			30	100 ⁽⁴⁾	ppm/ $^\circ\text{C}$
	Each timer, astable ⁽⁵⁾			150			90		
	Timer 1 – Timer 2			± 10			± 10		
Supply voltage sensitivity of timing interval	Each timer, monostable ⁽³⁾	$T_A = 25^\circ\text{C}$		0.1	0.5		0.05	0.2 ⁽⁴⁾	%/ V
	Each timer, astable ⁽⁵⁾			0.3			0.15		
	Timer 1 – Timer 2			± 0.2			± 0.1		
Output-pulse rise time		$C_L = 15\text{ pF}$, $T_A = 25^\circ\text{C}$		100	300		100	200 ⁽⁴⁾	ns
Output-pulse fall time		$C_L = 15\text{ pF}$, $T_A = 25^\circ\text{C}$		100	300		100	200 ⁽⁴⁾	ns

- (1) For conditions shown as MIN or MAX, use the appropriate value specified under recommended operating conditions.
- (2) Timing-interval error is defined as the difference between the measured value and the average value of a random sample from each process run.
- (3) Values specified are for a device in a monostable circuit similar to [Figure 2](#), with the following component values: $R_A = 2\text{ k}\Omega$ to $100\text{ k}\Omega$, $C = 0.1\text{ }\mu\text{F}$.
- (4) On products compliant to MIL-PRF-38535, this parameter is not production tested.
- (5) Values specified are for a device in an astable circuit similar to [Figure 1](#), with the following component values: $R_A = 1\text{ k}\Omega$ to $100\text{ k}\Omega$, $C = 0.1\text{ }\mu\text{F}$.

APPLICATION INFORMATION

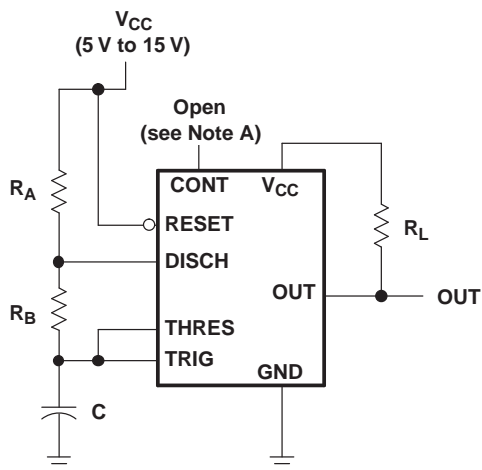

NOTE A: Bypassing the control-voltage input to ground with a capacitor might improve operation. This should be evaluated for individual applications.

Figure 1. Circuit for Astable Operation

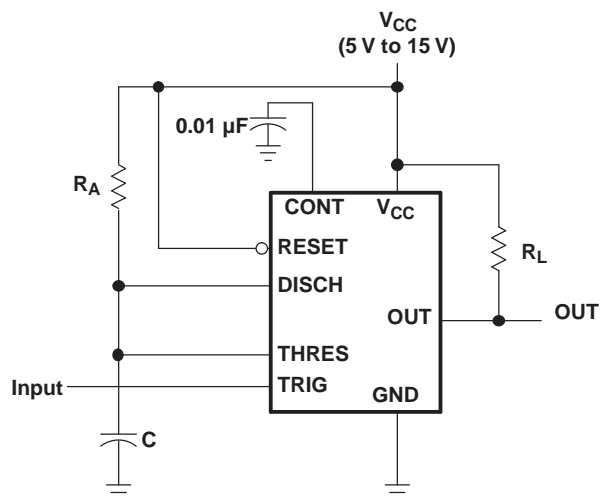

Figure 2. Circuit for Monostable Operation

PACKAGING INFORMATION

Orderable Device	Status ⁽¹⁾	Package Type	Package Drawing	Pins	Package Qty	Eco Plan ⁽²⁾	Lead/Ball Finish	MSL Peak Temp ⁽³⁾
JM38510/10902BCA	ACTIVE	CDIP	J	14	1	TBD	A42 SNPB	N / A for Pkg Type
NA556D	ACTIVE	SOIC	D	14	50	Green (RoHS & no Sb/Br)	CU NIPDAU	Level-1-260C-UNLIM
NA556DG4	ACTIVE	SOIC	D	14	50	Green (RoHS & no Sb/Br)	CU NIPDAU	Level-1-260C-UNLIM
NA556DR	ACTIVE	SOIC	D	14	2500	Green (RoHS & no Sb/Br)	CU NIPDAU	Level-1-260C-UNLIM
NA556DRG4	ACTIVE	SOIC	D	14	2500	Green (RoHS & no Sb/Br)	CU NIPDAU	Level-1-260C-UNLIM
NA556N	ACTIVE	PDIP	N	14	25	Pb-Free (RoHS)	CU NIPDAU	N / A for Pkg Type
NA556NE4	ACTIVE	PDIP	N	14	25	Pb-Free (RoHS)	CU NIPDAU	N / A for Pkg Type
NE556D	ACTIVE	SOIC	D	14	50	Green (RoHS & no Sb/Br)	CU NIPDAU	Level-1-260C-UNLIM
NE556DBR	ACTIVE	SSOP	DB	14	2000	Green (RoHS & no Sb/Br)	CU NIPDAU	Level-1-260C-UNLIM
NE556DBRE4	ACTIVE	SSOP	DB	14	2000	Green (RoHS & no Sb/Br)	CU NIPDAU	Level-1-260C-UNLIM
NE556DE4	ACTIVE	SOIC	D	14	50	Green (RoHS & no Sb/Br)	CU NIPDAU	Level-1-260C-UNLIM
NE556DR	ACTIVE	SOIC	D	14	2500	Green (RoHS & no Sb/Br)	CU NIPDAU	Level-1-260C-UNLIM
NE556DRE4	ACTIVE	SOIC	D	14	2500	Green (RoHS & no Sb/Br)	CU NIPDAU	Level-1-260C-UNLIM
NE556N	ACTIVE	PDIP	N	14	25	Pb-Free (RoHS)	CU NIPDAU	N / A for Pkg Type
NE556NE4	ACTIVE	PDIP	N	14	25	Pb-Free (RoHS)	CU NIPDAU	N / A for Pkg Type
NE556NSR	ACTIVE	SO	NS	14	2000	Green (RoHS & no Sb/Br)	CU NIPDAU	Level-1-260C-UNLIM
NE556NSRE4	ACTIVE	SO	NS	14	2000	Green (RoHS & no Sb/Br)	CU NIPDAU	Level-1-260C-UNLIM
SA556D	OBSOLETE	SOIC	D	14		TBD	Call TI	Call TI
SA556DR	OBSOLETE	SOIC	D	14		TBD	Call TI	Call TI
SA556N	ACTIVE	PDIP	N	14	25	Pb-Free (RoHS)	CU NIPDAU	N / A for Pkg Type
SA556NE4	ACTIVE	PDIP	N	14	25	Pb-Free (RoHS)	CU NIPDAU	N / A for Pkg Type
SE556FKB	OBSOLETE	LCCC	FK	20		TBD	Call TI	Call TI
SE556J	ACTIVE	CDIP	J	14	1	TBD	A42 SNPB	N / A for Pkg Type
SE556JB	ACTIVE	CDIP	J	14	1	TBD	A42 SNPB	N / A for Pkg Type

⁽¹⁾ The marketing status values are defined as follows:

ACTIVE: Product device recommended for new designs.

LIFEBUY: TI has announced that the device will be discontinued, and a lifetime-buy period is in effect.

NRND: Not recommended for new designs. Device is in production to support existing customers, but TI does not recommend using this part in a new design.

PREVIEW: Device has been announced but is not in production. Samples may or may not be available.

OBSOLETE: TI has discontinued the production of the device.

(2) Eco Plan - The planned eco-friendly classification: Pb-Free (RoHS), Pb-Free (RoHS Exempt), or Green (RoHS & no Sb/Br) - please check <http://www.ti.com/productcontent> for the latest availability information and additional product content details.

TBD: The Pb-Free/Green conversion plan has not been defined.

Pb-Free (RoHS): TI's terms "Lead-Free" or "Pb-Free" mean semiconductor products that are compatible with the current RoHS requirements for all 6 substances, including the requirement that lead not exceed 0.1% by weight in homogeneous materials. Where designed to be soldered at high temperatures, TI Pb-Free products are suitable for use in specified lead-free processes.

Pb-Free (RoHS Exempt): This component has a RoHS exemption for either 1) lead-based flip-chip solder bumps used between the die and package, or 2) lead-based die adhesive used between the die and leadframe. The component is otherwise considered Pb-Free (RoHS compatible) as defined above.

Green (RoHS & no Sb/Br): TI defines "Green" to mean Pb-Free (RoHS compatible), and free of Bromine (Br) and Antimony (Sb) based flame retardants (Br or Sb do not exceed 0.1% by weight in homogeneous material)

(3) MSL, Peak Temp. -- The Moisture Sensitivity Level rating according to the JEDEC industry standard classifications, and peak solder temperature.

Important Information and Disclaimer:The information provided on this page represents TI's knowledge and belief as of the date that it is provided. TI bases its knowledge and belief on information provided by third parties, and makes no representation or warranty as to the accuracy of such information. Efforts are underway to better integrate information from third parties. TI has taken and continues to take reasonable steps to provide representative and accurate information but may not have conducted destructive testing or chemical analysis on incoming materials and chemicals. TI and TI suppliers consider certain information to be proprietary, and thus CAS numbers and other limited information may not be available for release.

In no event shall TI's liability arising out of such information exceed the total purchase price of the TI part(s) at issue in this document sold by TI to Customer on an annual basis.

J (R-GDIP-T**)

14 LEADS SHOWN

CERAMIC DUAL IN-LINE PACKAGE



DIM \ PINS **	14	16	18	20
A	0.300 (7,62) BSC	0.300 (7,62) BSC	0.300 (7,62) BSC	0.300 (7,62) BSC
B MAX	0.785 (19,94)	.840 (21,34)	0.960 (24,38)	1.060 (26,92)
B MIN	—	—	—	—
C MAX	0.300 (7,62)	0.300 (7,62)	0.310 (7,87)	0.300 (7,62)
C MIN	0.245 (6,22)	0.245 (6,22)	0.220 (5,59)	0.245 (6,22)



4040083/F 03/03

- NOTES:
- A. All linear dimensions are in inches (millimeters).
 - B. This drawing is subject to change without notice.
 - C. This package is hermetically sealed with a ceramic lid using glass frit.
 - D. Index point is provided on cap for terminal identification only on press ceramic glass frit seal only.
 - E. Falls within MIL STD 1835 GDIP1-T14, GDIP1-T16, GDIP1-T18 and GDIP1-T20.

FK (S-CQCC-N**)

LEADLESS CERAMIC CHIP CARRIER

28 TERMINAL SHOWN



4040140/D 10/96

- NOTES:
- A. All linear dimensions are in inches (millimeters).
 - B. This drawing is subject to change without notice.
 - C. This package can be hermetically sealed with a metal lid.
 - D. The terminals are gold plated.
 - E. Falls within JEDEC MS-004

N (R-PDIP-T**)

PLASTIC DUAL-IN-LINE PACKAGE

16 PINS SHOWN



- NOTES:
- A. All linear dimensions are in inches (millimeters).
 - B. This drawing is subject to change without notice.
 - Falls within JEDEC MS-001, except 18 and 20 pin minimum body length (Dim A).
 - The 20 pin end lead shoulder width is a vendor option, either half or full width.

D (R-PDSO-G14)

PLASTIC SMALL-OUTLINE PACKAGE

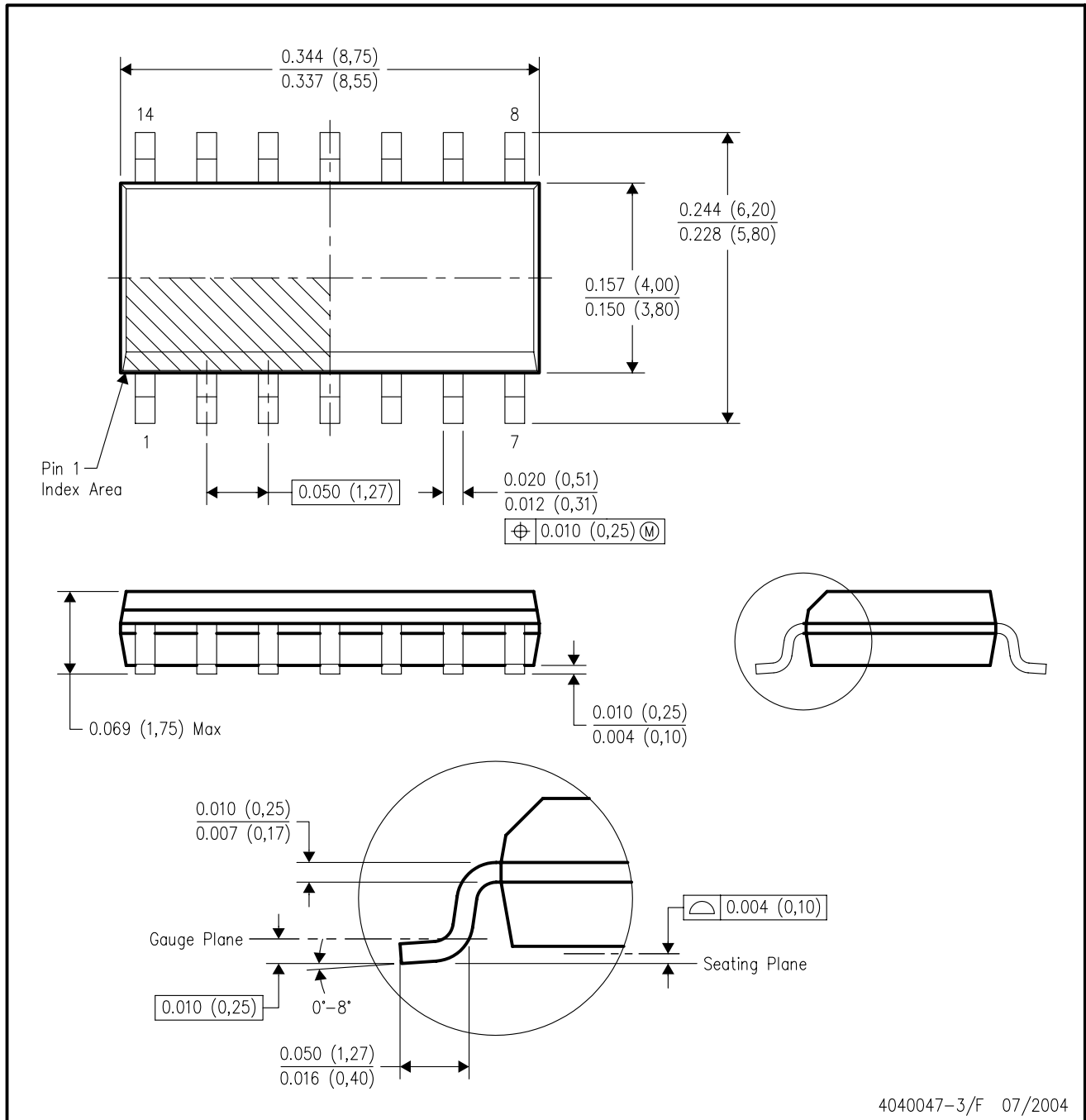

4040047-3/F 07/2004

- NOTES:
- A. All linear dimensions are in inches (millimeters).
 - B. This drawing is subject to change without notice.
 - C. Body dimensions do not include mold flash or protrusion not to exceed 0.006 (0,15).
 - D. Falls within JEDEC MS-012 variation AB.

MECHANICAL DATA

NS (R-PDSO-G**)

PLASTIC SMALL-OUTLINE PACKAGE

14-PINS SHOWN



- NOTES:
- A. All linear dimensions are in millimeters.
 - B. This drawing is subject to change without notice.
 - C. Body dimensions do not include mold flash or protrusion, not to exceed 0,15.

DB (R-PDSO-G**)

PLASTIC SMALL-OUTLINE

28 PINS SHOWN



- NOTES: A. All linear dimensions are in millimeters.
 B. This drawing is subject to change without notice.
 C. Body dimensions do not include mold flash or protrusion not to exceed 0,15.
 D. Falls within JEDEC MO-150

IMPORTANT NOTICE

Texas Instruments Incorporated and its subsidiaries (TI) reserve the right to make corrections, modifications, enhancements, improvements, and other changes to its products and services at any time and to discontinue any product or service without notice. Customers should obtain the latest relevant information before placing orders and should verify that such information is current and complete. All products are sold subject to TI's terms and conditions of sale supplied at the time of order acknowledgment.

TI warrants performance of its hardware products to the specifications applicable at the time of sale in accordance with TI's standard warranty. Testing and other quality control techniques are used to the extent TI deems necessary to support this warranty. Except where mandated by government requirements, testing of all parameters of each product is not necessarily performed.

TI assumes no liability for applications assistance or customer product design. Customers are responsible for their products and applications using TI components. To minimize the risks associated with customer products and applications, customers should provide adequate design and operating safeguards.

TI does not warrant or represent that any license, either express or implied, is granted under any TI patent right, copyright, mask work right, or other TI intellectual property right relating to any combination, machine, or process in which TI products or services are used. Information published by TI regarding third-party products or services does not constitute a license from TI to use such products or services or a warranty or endorsement thereof. Use of such information may require a license from a third party under the patents or other intellectual property of the third party, or a license from TI under the patents or other intellectual property of TI.

Reproduction of information in TI data books or data sheets is permissible only if reproduction is without alteration and is accompanied by all associated warranties, conditions, limitations, and notices. Reproduction of this information with alteration is an unfair and deceptive business practice. TI is not responsible or liable for such altered documentation.

Resale of TI products or services with statements different from or beyond the parameters stated by TI for that product or service voids all express and any implied warranties for the associated TI product or service and is an unfair and deceptive business practice. TI is not responsible or liable for any such statements.

Following are URLs where you can obtain information on other Texas Instruments products and application solutions:

Products		Applications	
Amplifiers	amplifier.ti.com	Audio	www.ti.com/audio
Data Converters	dataconverter.ti.com	Automotive	www.ti.com/automotive
DSP	dsp.ti.com	Broadband	www.ti.com/broadband
Interface	interface.ti.com	Digital Control	www.ti.com/digitalcontrol
Logic	logic.ti.com	Military	www.ti.com/military
Power Mgmt	power.ti.com	Optical Networking	www.ti.com/opticalnetwork
Microcontrollers	microcontroller.ti.com	Security	www.ti.com/security
Low Power Wireless	www.ti.com/lpw	Telephony	www.ti.com/telephony
		Video & Imaging	www.ti.com/video
		Wireless	www.ti.com/wireless

Mailing Address: Texas Instruments
Post Office Box 655303 Dallas, Texas 75265