

DT8211

LCD Back Light Inverter Drive IC

Rev1.1 – 11 July 2008

1. General description

The DT8211 is a LCD backlight inverter controller for driving CCFL (Cold Cathode Fluorescent Lamp). It drives a half bridge topology symmetrically and provides a near sinusoidal current waveform. It operates at a single-stage topology, constant frequency PWM (Pulse Width Modulation) mode. The MaxDuty technique achieves the maximum duty ratio of about 48% and hence can provide better efficiency. A typical operating frequency ranges from 30kHz to 300kHz, depending on the CCFL and transformer characteristics. Features such as OLP (Open Lamp Protection) and SCP (Short Circuit Protection) functions are included. It is available in 18-pin SOPW.

2. Features

- High Efficiency Single Stage Power Conversion
- P- and N-channel MOSFET Driver Included
- Wide Input Supply Voltage Range from 7.5V to 45V
- Maximum Duty ratio of 48%
- Extremely Low Number of External Components
- Extremely Small Size of Board
- Constant Frequency PWM Operation
- High Precision Oscillator
- Analog and Burst Dimming Function Simultaneously
- Analog Dimming Polarity Selectable
- Burst Dimming Polarity Selectable
- Open Lamp Protection Circuit Included
- Output Short Circuit Protection Circuit Included
- 18 Pin SOPW

3. Applications

- LCD Backlight Inverter
- EEFL Inverter
- FFL Inverter
- Advertisement Board

4. Package information

Type number	Package		
	Name	Description	Marking
DT8211	18 SOPW	18 Lead SOP Wide Body	DT8211

5. Typical Application

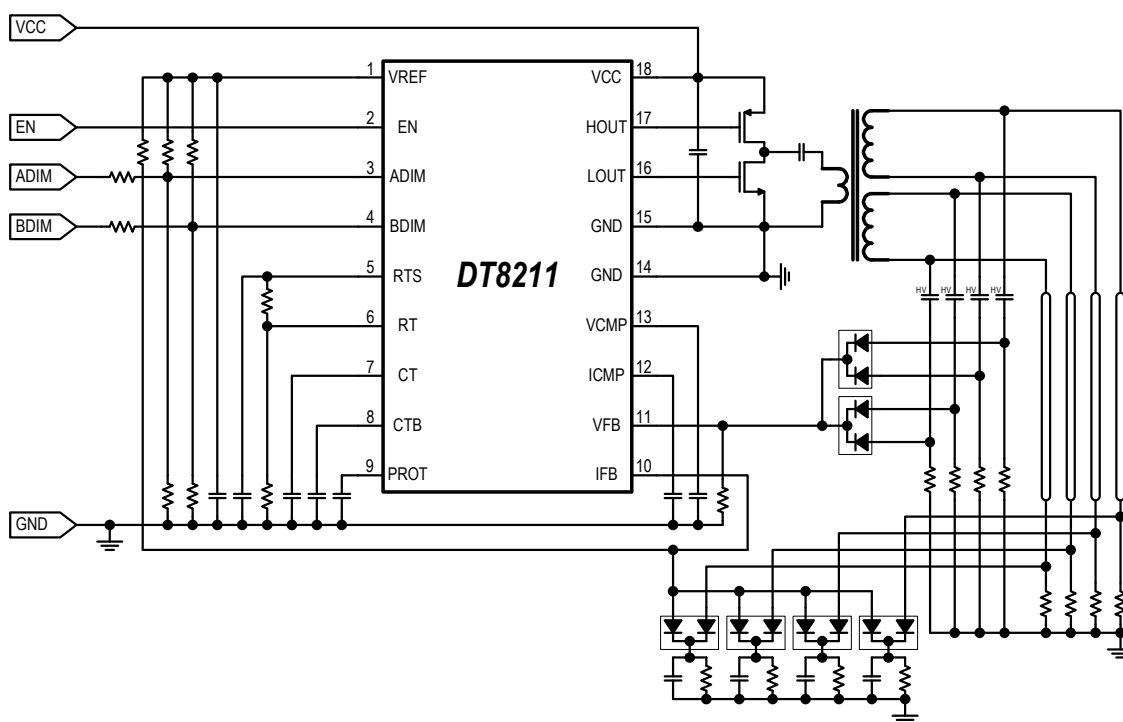

6. Pinning information

Top View

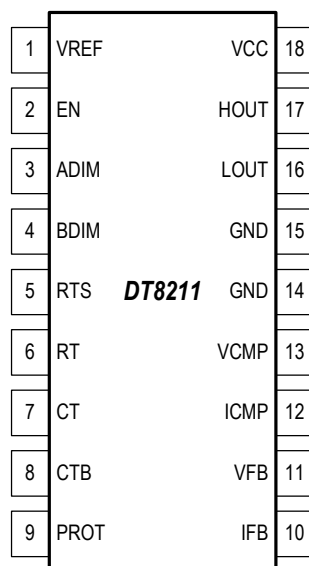

Pin	Symbol	I/O	Description
1	VREF	O	Reference Voltage (VREF) = 6V
2	EN	I	ON/OFF Control Pin
3	ADIM	I	Analog Dimming Pin (Positive and Negative Mode)
4	BDIM	I	Burst Dimming Pin (Positive and Negative Mode)
5	RTS	O	Frequency Setting Resistor for Striking PWM Frequency
6	RT	O	Frequency Setting Resistor for Main PWM Frequency
7	CT	O	Frequency Setting Capacitor for Main PWM Frequency
8	CTB	O	Frequency Setting Capacitor for Burst Dimming Frequency
9	PROT	I	Protection Pin
10	IFB	I	Feedback Input for Current Regulation
11	VFB	I	Feedback Input for Voltage Regulation
12	ICMP	O	Error Amplifier Output for Current Regulation
13	VCMP	O	Error Amplifier Output for Voltage Regulation
14,15	GND	I	Ground
16	LOUT	O	Low Side Gate Driver Output
17	HOUT	O	High Side Gate Driver Output
18	VCC	I	Supply Voltage

7. Absolute maximum ratings

If Military/Aerospace specified devices are required, please contact the DMB technology Sales Office/Distributors for availability and specifications.

Parameter	Symbol	Value	Unit
Supply Voltage	V_{CC}	45	V
Power Dissipation	P_D	1.9	W
Operating Ambient Temperature	T_A	-30~+85	°C
Operating Junction Temperature	T_J	-30~+150	°C
Thermal Resistance Junction to Ambient	θ_{JA}	66.6	°C/W
Storage Temperature	T_{STG}	-40~+125	°C

8. Electrical characteristics

$T_A = 25^\circ\text{C}$, $V_{CC} = 15\text{V}$, unless otherwise specified

Parameter	Symbol	Conditions	Min	Typ	Max	Unit
Reference section						
Reference Voltage	V_{REF}		5.85	6.0	6.15	V
Max V_{REF} Current	I_{REF}		30			mA
Voltage Error amplifier section						
V. Amp. Transconductance	G_{mV}		24	30	36	uS
Feedback reference Voltage	$V_{V,REF}$		1.94	2.0	2.06	V
Output Clamp Voltage	$V_{V,CLMP}$		3.05	3.2	3.35	V
Maximum Sinking Current	$I_{V,SNK}$		14	20	26	μA
Maximum Sourcing Current	$I_{V,SRC}$		14	20	26	μA
High VFB Sinking Current	$I_{V,SNKH}$	when VFB > 2.5V	70	150	200	μA
Current Error amplifier section						
I. Amp. Transconductance	G_{mI}		120	150	180	uS
Max. Feedback Ref. Voltage	$V_{I,MAX}$		1.94	2.0	2.06	V
Maximum Sinking Current	$I_{I,SNK}$		70	100	130	μA
Maximum Sourcing Current	$I_{I,SRC}$		70	100	130	μA

8. Electrical characteristics

$T_A = 25^\circ\text{C}$, $V_{CC} = 15\text{V}$, unless otherwise specified

Parameter	Symbol	Conditions	Min	Typ	Max	Unit
Main oscillator section						
RT Voltage	V_{RT}		1.96	2.0	2.04	V
CT Oscillation Frequency	F_{CT}	when $R_T > 20\text{k}\Omega$	97	100	103	kHz
Main Oscillation Frequency	F_{MAIN}		48.5	50	51.5	kHz
Triangular High Voltage	V_{HM}		2.8	3.0	3.2	V
Triangular Low Voltage	V_{LM}		1.0	1.2	1.4	V
Burst oscillator section						
Burst Oscillation Frequency	F_{oscb}	when $R_T > 20\text{k}\Omega$	291	300	309	Hz
Triangular High Voltage	V_{HB}		1.9	2.0	2.1	V
Triangular Low Voltage	V_{LB}		0.7	0.8	0.9	V
Dimming section						
ADIM Input Impedance	R_{ADIM}		80	100	120	$\text{K}\Omega$
BDIM Input Impedance	R_{BDIM}		80	100	120	$\text{K}\Omega$
ADIM Int. Bias Voltage	$V_{ADIM,B}$		2.4	2.5	2.6	V
BDIM Int. Bias Voltage	$V_{BDIM,B}$		2.4	2.5	2.6	V
Protection section						
Init. PROT Discharging I.	$I_{PROT,INI}$		3			mA
PROT Charging Current	$I_{PROT,CG}$		0.35	0.5	0.65	μA
PROT Threshold Voltage	V_{PROT}		2.8	3.0	3.2	V
IFB Open Lamp Detect V.	$V_{OLP,IFB}$		0.65	0.75	0.85	V
ICMP Striking Mode V.	$V_{STK,ICMP}$	when $IFB < 0.75\text{V}$	3.2	3.5	3.8	V
General						
Enable On Voltage	$V_{EN,ON}$		2.0			V
Enable Off Voltage	$V_{EN,OFF}$				0.8	V
Quiescent Current	I_{CC}			7.0		mA
Maximum Oscillation Duty	D_{MAX}			48		%
Output section						
P-CH Output High Voltage	V_{POH}	$I_{SINK} = 200\mu\text{A}$	$V_{CC} - 0.5$	$V_{CC} - 0.1$	V_{CC}	V
P-CH Output Low Voltage	V_{POL}	$I_{SOURCE} = 200\mu\text{A}$	$V_{CC} - 14$	$V_{CC} - 12$	$V_{CC} - 10$	V
N-CH Output High Voltage	V_{NOH}	$I_{SINK} = 200\mu\text{A}$	10.0	12.0	14.0	V
N-CH Output Low Voltage	V_{NOL}	$I_{SOURCE} = 200\mu\text{A}$	0	0.1	0.5	V

9. Block Diagram

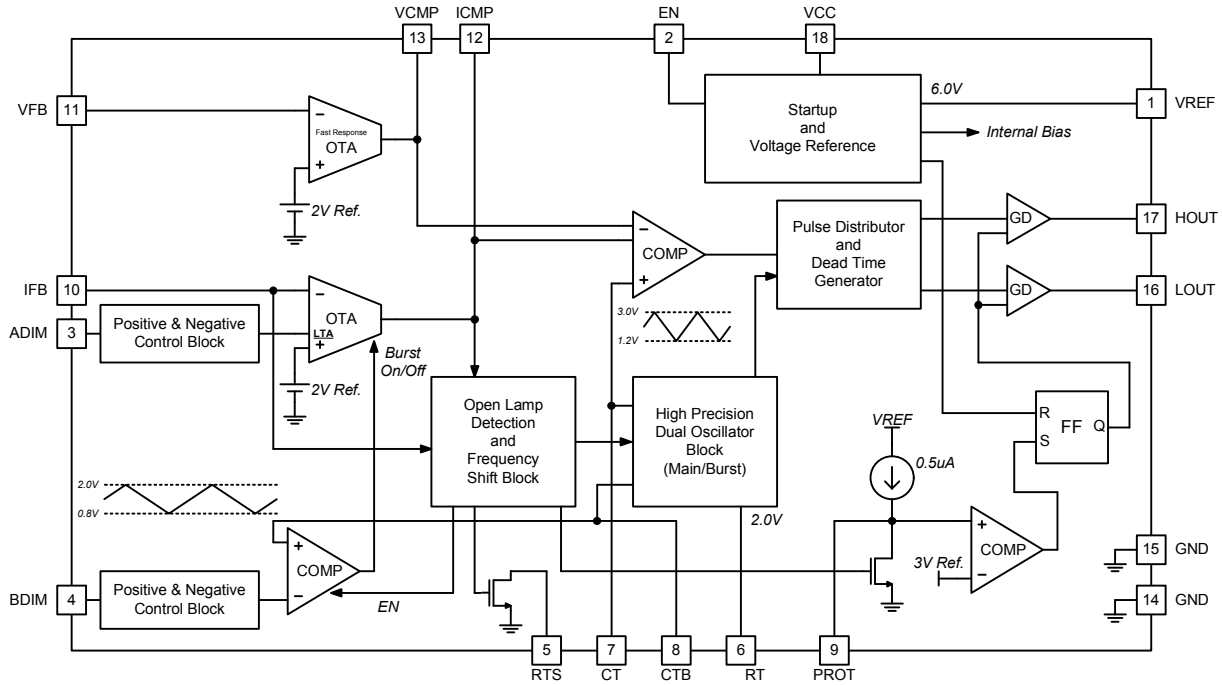

10. Functional Description

Internal Regulator

To supply a stable power to internal and external circuit, a high precise regulator is included. It makes 6.0V over the full range of input supply voltage. This also supplies a stable voltage to internal analog critical circuit, to make stable operation. VREF is an output of internal regulator, and can supply over 30mA to external circuit.

Chip Enable

When EN pin is over $V_{EN,ON}$, the internal regulator is turned on. Therefore internal and external circuits begin to operate. Since it has over 100mV hysteresis, unpredictable operation is protected.

Main Frequency Oscillator

To generate clear PWM pulse, DT8211 includes a precise triangular waveform generator circuit. The voltage of RT pin is fixed at 2.0V and the current of RT pin is flow through the resistor which is connected between RT pin and GND. This current makes charging and discharging current of a capacitor which is connected to CT pin and GND. Triangular wave is generated at CT pin by charging and discharging (repeated operation) to this capacitor. This triangular wave is one of reference signal to generate PWM. The frequency of triangular wave can be calculated approximately as below and is 2 times of lamp frequency.

$$f_{Main} [Hz] = \frac{0.232}{R_T \cdot C_T}$$

10. Functional Description (Continued)

Striking Frequency

Striking frequency is generated by increasing charging and discharging current of a capacitor (CT). RTS pin is normally high impedance, but it goes low when DT8211 is in striking mode. If a resistor is connected between RTS and RT, a striking frequency can be generated by increased current and the equation is as below.

$$f_{Striking} [Hz] = \frac{0.228(R_T + R_{TS})}{R_T \cdot R_{TS} \cdot C_T}$$

Burst Frequency Oscillator

To generate clear PWM pulse, DT8211 includes a precise triangular waveform generator circuit. The voltage of RT pin is fixed at 2.0V and the current of RT pin is flow through the resistor which is connected between RT pin and GND. This current makes charging and discharging current of a capacitor which is connected to CTB pin and GND. Triangular wave is generated at CTB pin by charging and discharging (repeated operation) to this capacitor. This triangular wave is one of reference signal to generate PWM. The frequency of triangular wave can be calculated approximately as below.

$$f_{Burst} [Hz] = \frac{0.11}{R_T \cdot C_{TB}}$$

Analog Dimming

DT8211 includes three kinds of dimming method. One is analog dimming, burst dimming and pulse dimming. Analog dimming command feeds DC level to ADIM pin which is a positive input of internal error amplifier. When $0V < V_{ADIM} < 2.0V$, DT8211 operates in positive polarity mode, but when $3.0V < V_{ADIM} < 5.0V$, DT8211 operates in negative polarity mode as below figure.

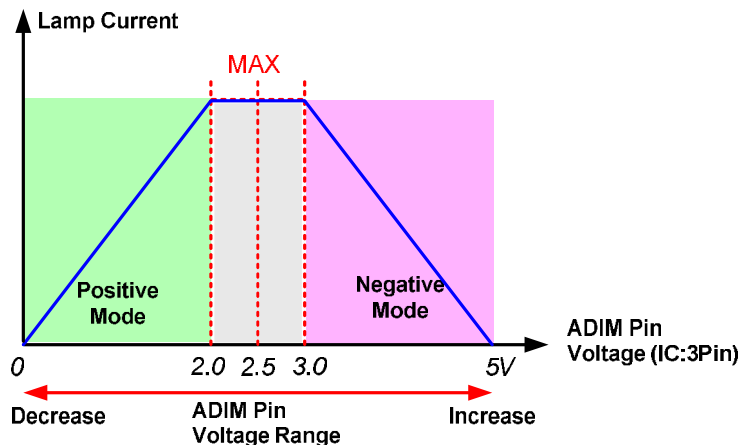

The negative input of error amplifier for current is IFB pin, and control loop is operated to make IFB level equal to ADIM level. The output of error amplifier for current, which is ICMP pin, is directly connected to main PWM generator.

10. Functional Description (Continued)

Burst Dimming

DT8211 includes three kinds of dimming method. One is analog dimming, burst dimming and pulse dimming. Burst dimming command feeds DC level to BDIM pin which is an input of internal PWM generator. When $0V < V_{BDIM} < 2.0V$, DT8211 operates in positive polarity mode, but when $3.0V < V_{BDIM} < 5.0V$, DT8211 operates in negative polarity mode as below figure.

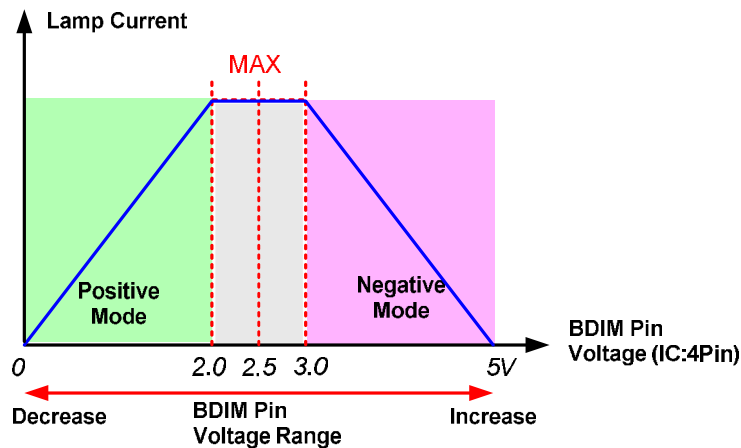

Burst PWM is generated using BDIM and triangular wave of CTB. The rising and falling slopes of BDIM operation are adjusted by capacitor which is connected between ICMP pin and GND. The source and sink currents of ICMP are 100uA. We recommend 300usec as rising and falling time.

Pulse Dimming

DT8211 includes three kinds of dimming method. One is analog dimming, burst dimming and pulse dimming. In this mode, PWM pulse of pulse dimming feeds to BDIM pin and a resistor must be connected between CTB and GND. When the pulse swings 0V to 2V, DT8211 operates in positive polarity mode, but when the pulse swings 3V to 5V, DT8211 operates in negative polarity mode.

To operate pulse dimming mode, CTB must be a constant level. So a resistor is recommended between CTB and GND, and its value which makes CTB level to about 1.0V is recommended as below equation.

$$R_{CTB,PDIM} = 3.5 \times R_T$$

Main PWM Generator

The main PWM pulse is generated with ICMP, VCMP and CT. ICMP and VCMP are connected to comparator negative inputs of PWM generator, and CT is connected to comparator positive input of PWM generator. CT decides PWM frequency and ICMP and VCMP decide PWM Duty. Output duty of main PWM is limited approximately 48% when main frequency is 50kHz to prevent shoot-through of Power FETs.

10. Functional Description (Continued)

Protection (OLP, SCP)

Abnormal status is detected by IFB level. If IFB level goes under 0.75V, DT8211 became protection mode. This mode means that one or more of current feedback levels is very low. To change to normal operating mode, IFB level must be higher than 0.75V. In protection mode, a capacitor which is connected PROT pin is charged by 0.5uA. If PROT pin is over 3.0V, DT8211 will shutdown the outputs. To restart DT8211 after shutdown, EN or VCC must be low and go high. The time of protection is as below.

$$T_{PROT}[\text{sec}] = 6 \times 10^6 \cdot C_{PROT}$$

Striking Mode

Striking mode is a part of abnormal status. This mode is detected by IFB level and ICMP level. If IFB level goes under 0.75V and ICMP level goes over 3.5V, DT8211 became striking mode. (Of course striking mode must be occurred in protection mode.) This mode means lamp open status, so DT8211 try to increase output voltage by shifting operating frequency. In this mode, RTS goes to 0V and burst dimming signal is ignored. The striking frequency is decided as above description.

OVP (Over Voltage Protection)

OVP function is implemented by internal voltage error amplifier. The reference voltage is 2.0V and in over voltage status, VFB pin is regulated as 2.0V.

Soft Start

After enabling DT8211, all capacitors which are connected to DT8211 are charged to make startup. A capacitor which is connected to VCMP must be chosen as a large value such as 100~300nF for soft start.

Gate Driver

DT8211 includes P channel and N channel gate drivers. The swing voltage of driver output is approximately 12V and DT8211 can drive directly PowerFETs without external component.

11. Package outline

18-Lead SOPW

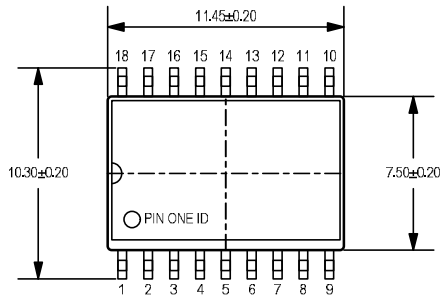

Note

1. Dimensions are in millimeters
2. Dimensions are exclusive of mold flash and interlead flash

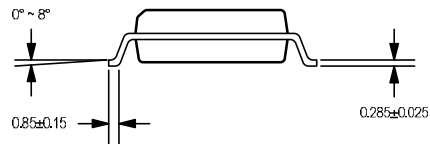
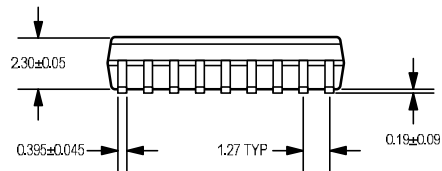

12. Important notices

- This products and its characteristic can be added or changed without notice. Before considering use or application, you'd better consult the D.M.B Technology Co., Ltd.
- No part of this publication may be reproduced or transmitted or copied in any form or by any means without permission of D.M.B Technology.
- Although our product has internal protective circuit, you'd better adopt safety circuits or measures externally to prevent undesired probabilistic device failure.
- D.M.B technology always strives to make a high quality and high reliability products.

13. Contact information

For technical information	icmozart@dmbtech.com
For sales information	sales@dmbtech.com
For additional information	http://www.dmbtech.com