

PIR612 - INTEGRATED PIR SENSOR FOR MOTION SENSING

PIR612 is the latest in PIR sensing, to be used in motion sensing applications with built in signal processing and digital output. Creating custom motion sensor can now be easily achieved. Some pins are output to adjust sensitivity and timings. LDR ambient light level can be added to switch off sensor during day time. Applications are security systems, burglar alarms, visitor acknowledgement, light switch control and smart toys.

DIMENSIONS & PINOUTS

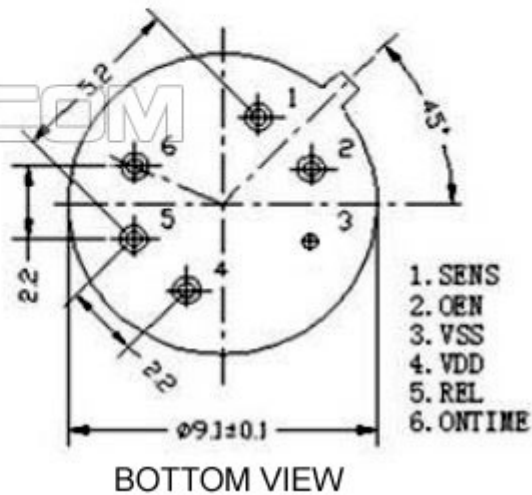
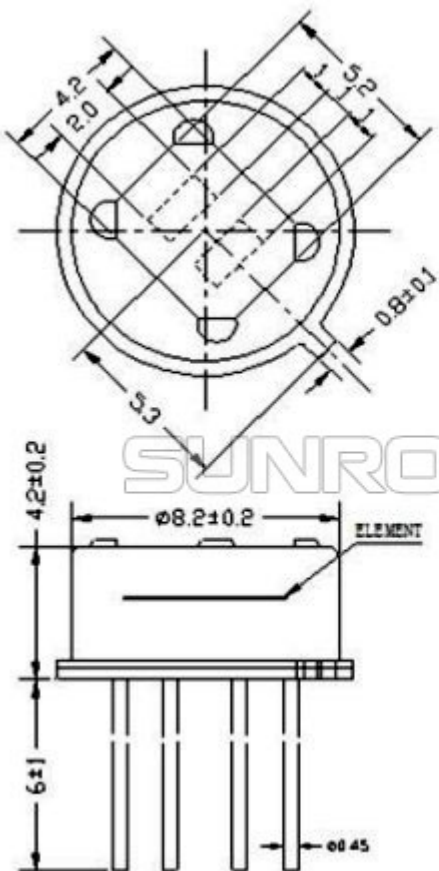

Dimensions

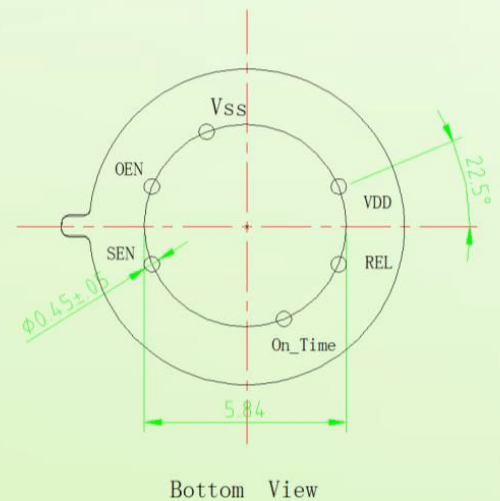
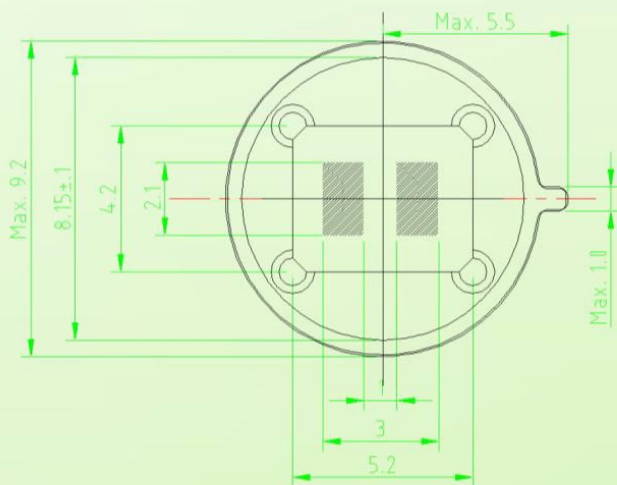

SPECIFICATIONS

Product Name	PIR Sensor with built in signal processing
Operating Voltage	2.7-3.3V DC
Operating Current	5mA
Window Size	4.2x5.2mm
Detecting Distance	6 to 8 meters
Type	Pyroelectric Infrared Sensor
Delay Time	2S-70min adjustable
Settling Time	At start up 15 seconds settling time/warm up
Operating Temperature	-20 C to +55 C
Humidity	10%-85%
Output Current	10mA Source/Sink maximum

Characteristics	Symb ol	Min.	Type	Max.	Unit	Remarks
Supply Voltage	V _{DD}	2.7		3.3	V	I _R =0.5mA
Regulated Current	I _R			5	mA	
Working Current ENREG=VDD	I _{DD}		25	30	μA	V _{DD} >3.3V
Working Current ENREG=VSS	I _{DD}		12	15	μA	V _{DD} <3.3V can not active
OEN						
Input Low Voltage	V _{IL}			0.6	V	
Input High Voltage	V _{IH}	1.2			V	
Input Current	I _I	-1		1	μA	V _{SS} < V _{IN} < V _{DD}
Output REL/LED						
Output Low Current	I _{OL}	10			mA	V _{OL} < 1V
Output High Current	I _{OH}			-10	mA	V _{OL} > (V _{DD} -1V)
Input SENS/ONTIME						
Voltage Input Range		0		V _{DD}	V	0V to ¼ V _{DD}
Input Bias Current		-1		1	μA	
Oscillator & Filter						
Low pass filter cut-off frequency				7	Hz	
High pass filter cut-off frequency				0.44	Hz	
Oscillator frequency on Chip	F _{CLK}			64	kHz	

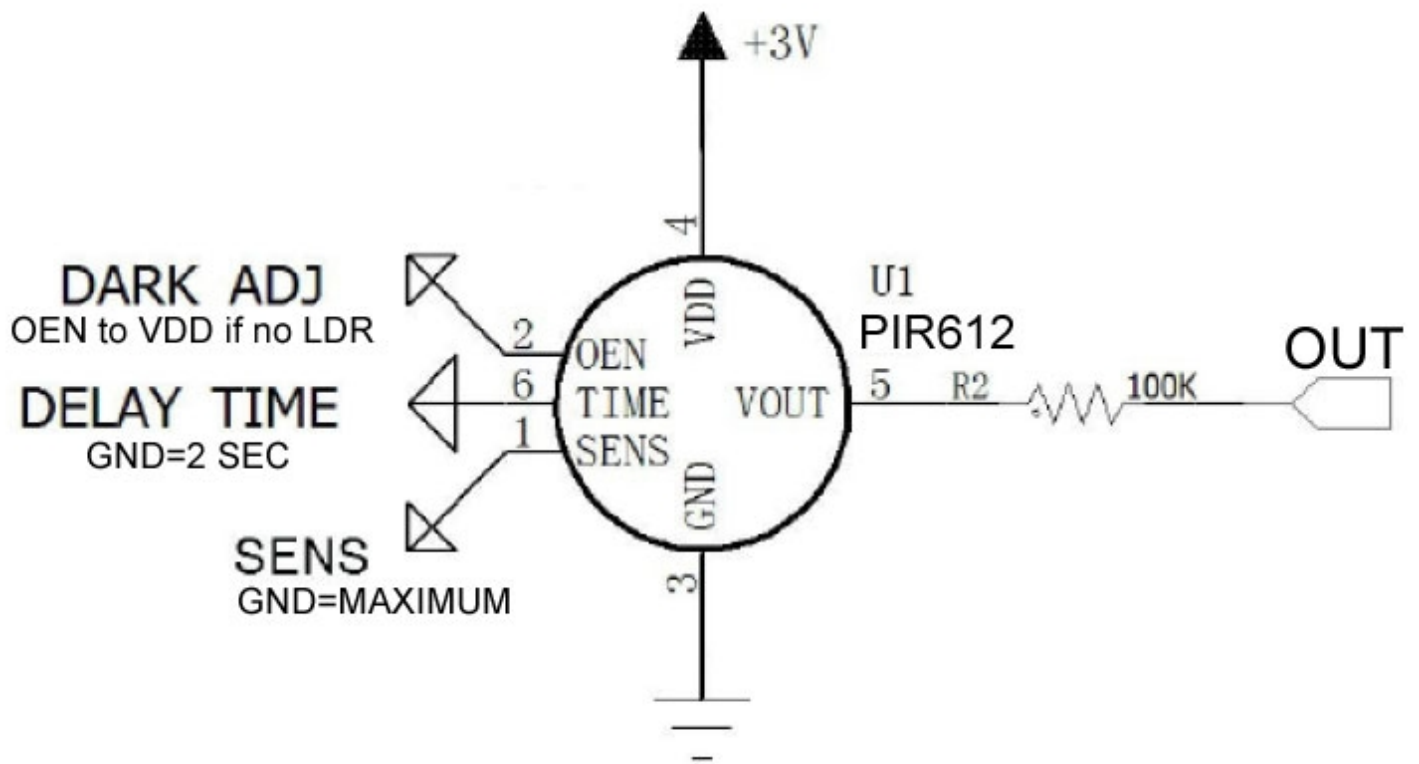

SENS: SENSITIVITY ADJUSTMENT

SENS pins decides how sensitive it is. Default put it to Ground (Maximum)

A voltage applied to the SENS input sets the threshold used to detect a PIR Signal. VSS selects the minimum threshold voltage. Any voltage above $VDD/4$ will select the maximum threshold, which is the least sensitive setting for PIR signal detection.

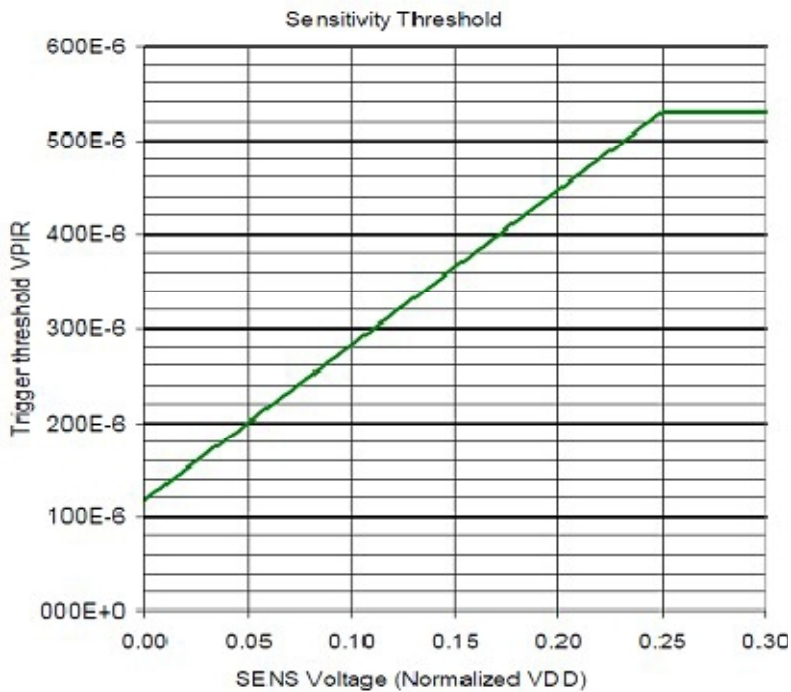

OEN: LDR LIGHT ADJUSTMENT

OEN pins switches off sensor for example during day time with help of an external LDR.

Connect OEN pin to VDD if not using LDR function.

If VDD=3V, and voltage rises from low to high, when it is higher than $0.4V_{DD}$ (1.2V), Vout enables. Voltage decreases from high to low, when lower than $0.2V_{DD}$ (0.6V), Vout disables.

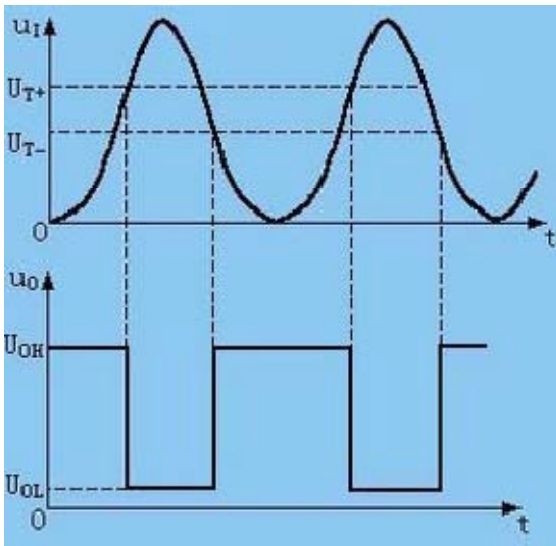

TIME: DELAY TIME

TIME pin decides how much time the output is high after trigger. Connect pin to ground for 2 seconds after trigger

Delay time adjustment

Pin voltage	PIN ADC count	On time in seconds	On time	Pull-up resistor	Pull-down resistor
$V_{dd} * 1/128$ or less	0	2	2 sec	Connect GND	
$V_{dd} * 3/128$	1	4	4sec		
$V_{dd} * 5/128$	2	6	6sec		
$V_{dd} * 7/128$	3	8	8 sec	1M	62K
$V_{dd} * 9/128$	4	16	16sec	1M	75K
$V_{dd} * 11/128$	5	33	32 sec	1M	91K
$V_{dd} * 13/128$	6	49	49 sec	1M	110K
$V_{dd} * 15/128$	7	66	1mini 5 sec	1M	130K
$V_{dd} * 17/128$	8	131	2 min 11 sec		
$V_{dd} * 19/128$	9	262	4 min 22 sec		
$V_{dd} * 21/128$	10	393	6 min 33 sec		
$V_{dd} * 23/128$	11	524	8 min 44 sec		
$V_{dd} * 25/128$	12	1049	17 min 28 sec		
$V_{dd} * 27/128$	13	2097	34 min 57 sec		
$V_{dd} * 29/128$	14	3146	52 min 25 sec		
$V_{dd} * 31/128$ or above	15	4194	1hour 10min	Connect VDD	

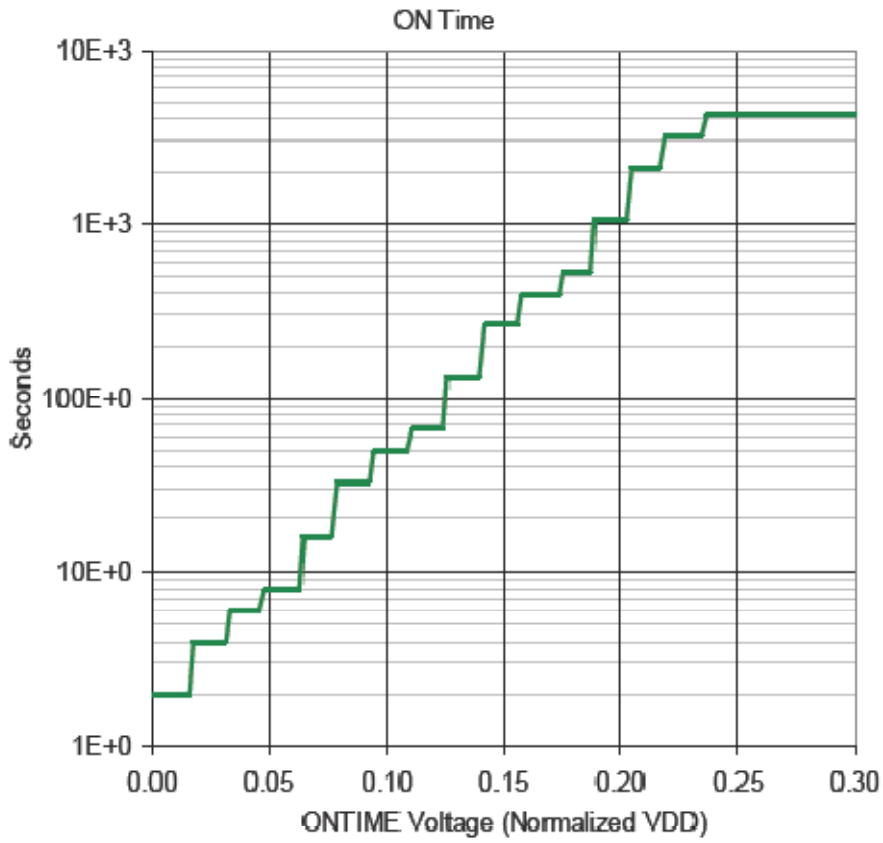

Graph 2: REL Output On Time in seconds vs. ONTIME pin voltages normalized to VDD.

REFERENCE DESIGN #1: AC OPERATED PIR LIGHT SWITCH

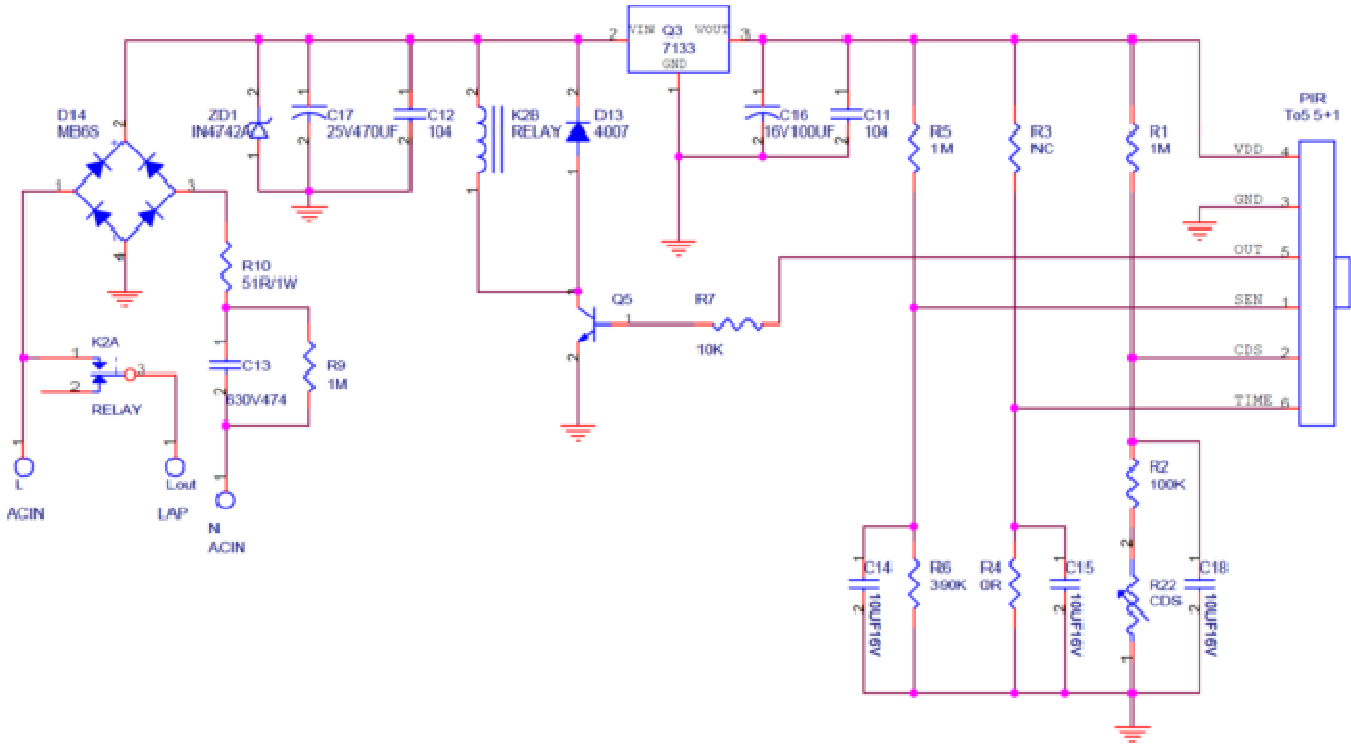

REFERENCE DESIGN #2: DC OPERATED RELAY

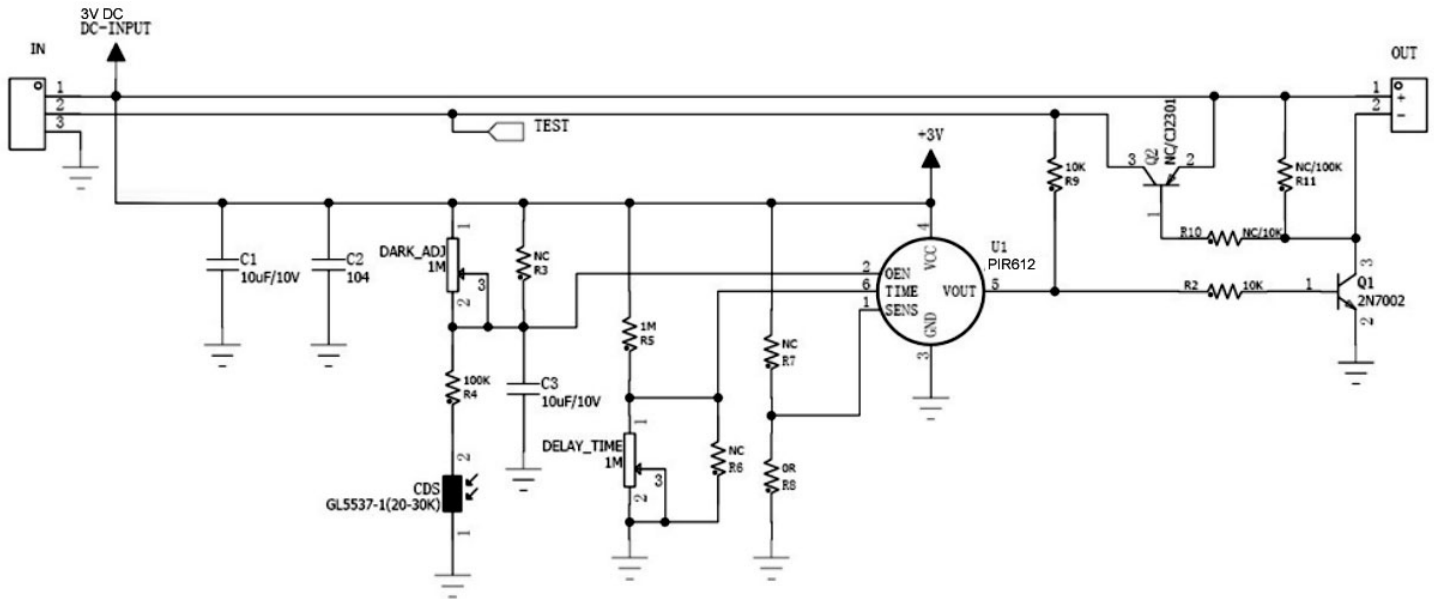

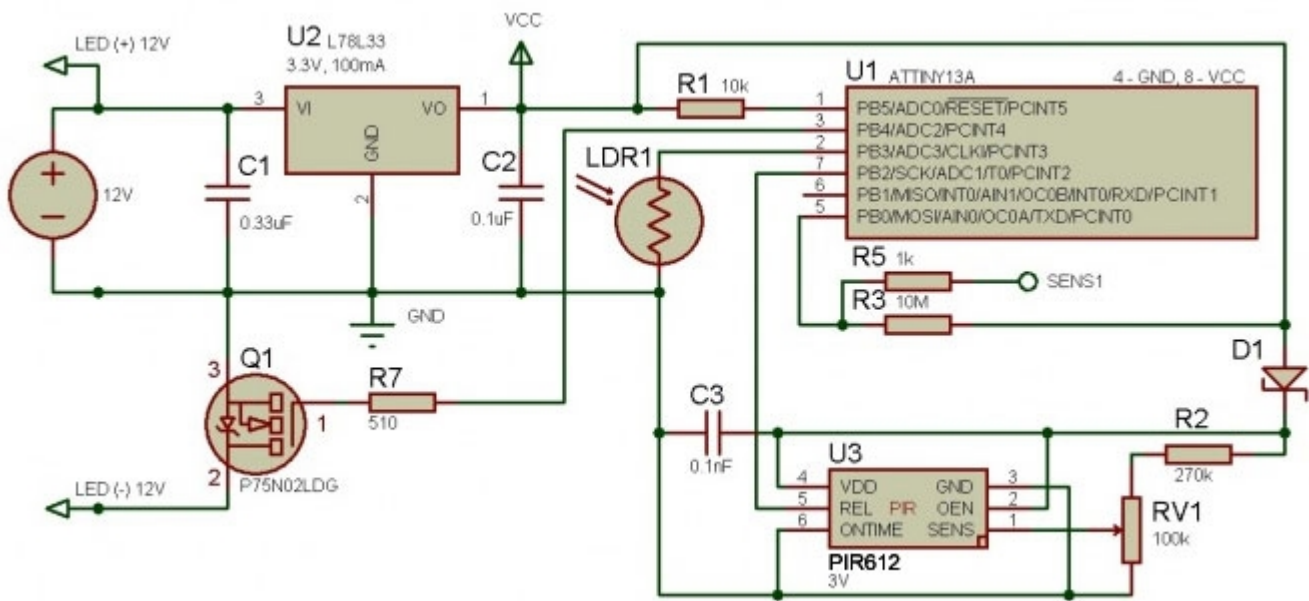

Note

Due to the high sensitivity of PIR sensor device, it is not recommended to use the module in the following or similar condition.

- A) in rapid environmental changes
- B) in strong shock or vibration
- C) in a place where there are obstructing material (eg. glass) through which IR cannot pass within detection area.
- D) exposed to direct sun light
- E) exposed to direct wind from a heater or air condition

ORDERING DETAILS

Sunrom Part#	Item	Ordering Page
5466	PIR612	http://www.sunrom.com/m/5466
RELATED PRODUCTS		
5467	PIR Lens 9mm	http://www.sunrom.com/m/5467
4811	HT7533-1 SOT-89	http://www.sunrom.com/m/4811