



BK3254 Bluetooth Multimedia SoC Datasheet

Preliminary Specification

Approvals

<i>Name</i>	<i>Date</i>	<i>Signature</i>

Beken Corporation
41, 1387 Zhangdong Rd, Shanghai 201203, China
PHONE: (86)21 5108 6811
FAX: (86)21 6087 1089

This document contains information that may be proprietary to, and/or secrets of, Beken Corporation. The contents of this document should not be disclosed outside the companies without specific written permission.

Disclaimer: Descriptions of specific implementations are for illustrative purpose only, actual hardware implementation may differ.



Revision History

Rev.	Date	Author(s)	Remark
0.1	2015/8/25	Weifeng	Initial Draft based on BK3254 datasheet today
	2015/9/11	Weifeng	Swap USBP and USBN location
0.2	2015/12/8	Weifeng	Modify package information
0.3	2016/2/15	Weifeng	Update package to QFN48
0.4	2016/06/01	Donghui	Update Features and add new Package QFN32
0.5	2016/07/01	Donghui	Update SSOP24 Audio Version



Contents

- 1. General Description 4
 - 1.1. Features 4
 - 1.2. Applications 4
- 2. Pin Information 5
- 3. Functional Description..... 10
 - 3.1. GPIO 10
 - 3.2. PWM Timer and Watch Dog Timer..... 11
 - 3.3. Power Management..... 11
 - 3.4. MCU 11
 - 3.5. I2C and UART Interface..... 11
 - 3.6. FLASH Access Interface 11
 - 3.7. SPI..... 11
 - 3.8. SAR ADC and LED 12
 - 3.9. Audio Peripheral 12
 - 3.10. USB..... 12
 - 3.11. Bluetooth and FM 12
- 4. Electrical Characteristics 12
 - 4.1. Absolute Maximum Ratings 12
 - 4.2. Recommended Operating Conditions 12
 - 4.3. Typical Power Consumption..... 13
 - 4.4. Bluetooth Characteristics 13
 - 4.5. Audio Characteristics 13
- 5. Application Schematic 13
- 6. About the Qualification 13
- 7. Package Information 14
 - 7.1. QFN48..... 14
 - 7.2. SSOP24 15
 - 7.3. SSOP28 16
- 8. Ordering Information 17

1. General Description

The BK3254 chip is a highly integrated single-chip Bluetooth multimedia device. It integrates Bluetooth transceiver, FM receiver, SD-card interface, USB OTG, and high performance audio peripheral. The BK3254 cache based architecture enables it is fully programmable with any application, that it may be used for control and multimedia hybrid application.

1.1. Features

- Operation voltage from 2.8 V to 5.2 V
- Bluetooth 4.1 + EDR compliant
- -90 dBm sensitivity for 1 Mbps mode and 5 dBm transmit power
- -107 dBm sensitivity FM receiver
- 1-wire or 4-wires SD-card interface
- USB 2.0 host and device
- Integrated 90 dB SNR ADC and stereo DAC
- I2C,SPI and UART interface
- Bluetooth A2DP, AVRCP and HFP profile
- SSOP24, SSOP28, QFN48 , QFN32 package

1.2. Applications

- Multi-mode Bluetooth stereo speaker
- Bluetooth control and multimedia hybrid

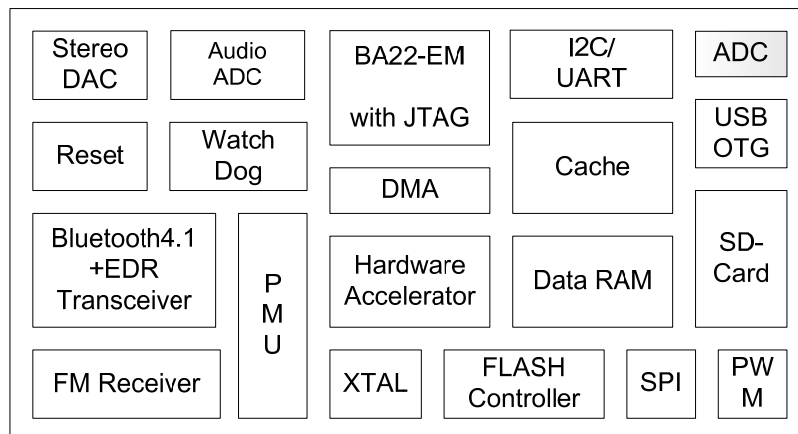

2. Pin Information

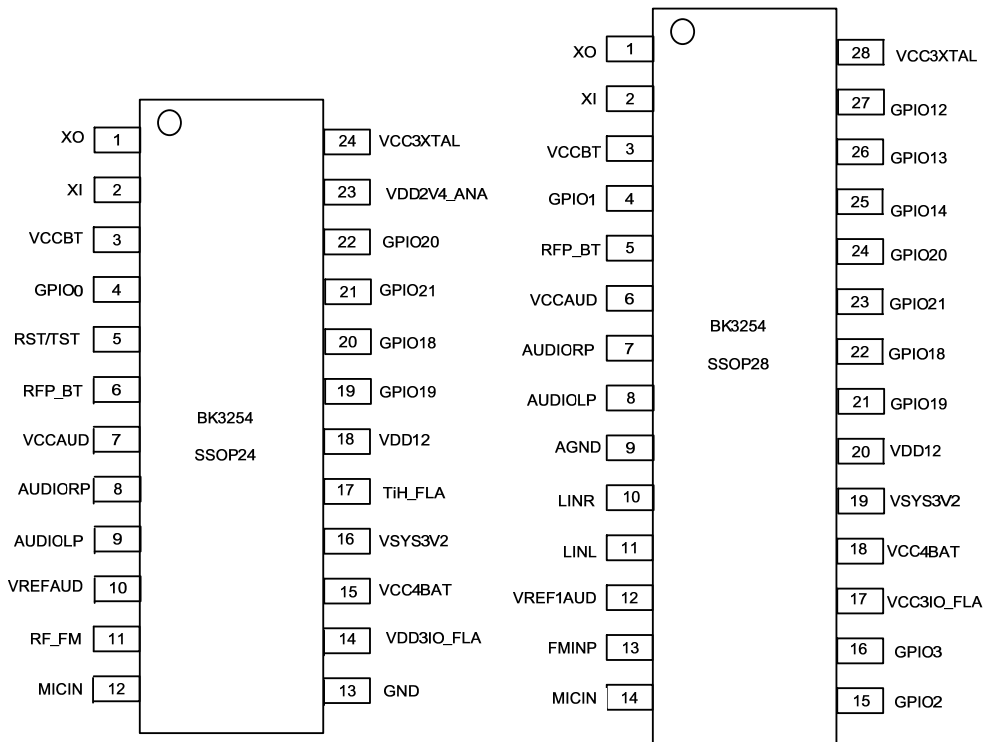
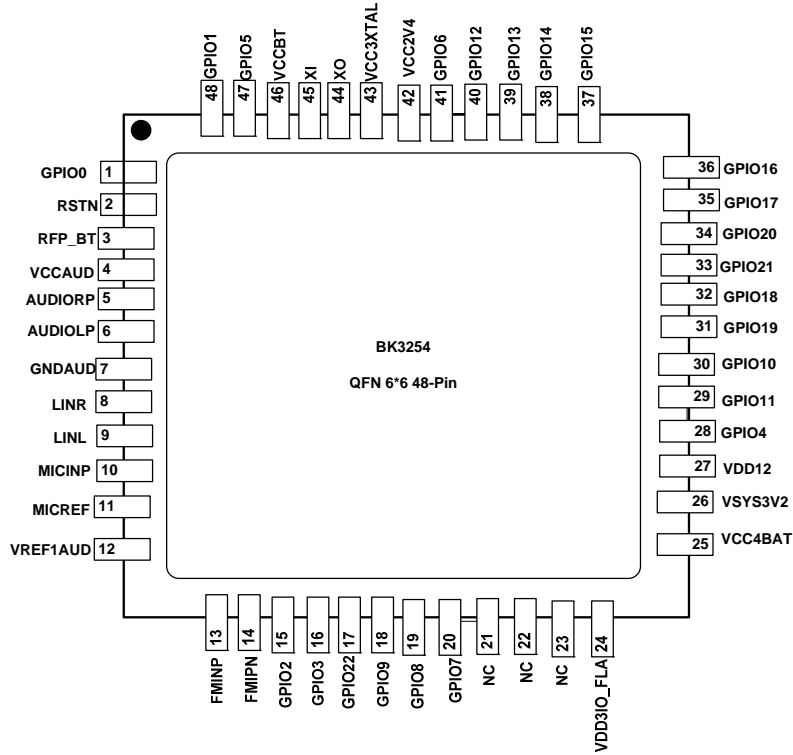

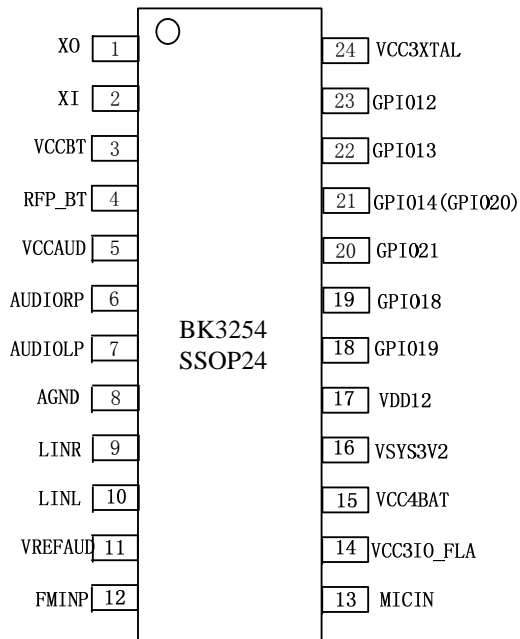

Table below has a pin description of the QFN 6x6 48-pin package, and for other package the pin with the same name as QFN has the same function.

Table 1 Pin Description

Package Pin #	Name	Description
1	GPIO0	GPIO 0
2	RSTN	Reset pin, active low
3	RFP_BT	Bluetooth RF Input and Output
4	VCCAUD	Audio power supply; Local 1uF decoupling cap
5	AUDIORP	Audio output right channel
6	AUDIOLP	Audio output left channel
7	GNDAUD	GND
8	LINR	Line input right channel
9	LINL	Line input left channel
10	MICINP	Microphone input positive
11	MICREF	Microphone input signal reference voltage
12	VREF1AUD	Audio reference; Connected to 4.7uF decoupling cap for high audio quality
13	FMINP	FM input positive
14	FMINN	FM input negative



BK3254 Datasheet

v 0.5

15	USBP(GPIO2)	USB positive or GPIO 2
16	USBN(GPIO3)	USB negative or GPIO 3
17	GPIO22	GPIO 22
18	GPIO9	GPIO 9
19	GPIO8(HD_FL A)	FLASH hold signal
20	GPIO7(WP_FL A)	FLASH write protection
21	NC	NC
22	NC	NC
23	NC	GND
24	VDD3IO_FL A	LDO output for FLASH, 3 V by default, local 1uF decoupling cap
25	VCC4BAT	Battery power input, 2.8 V ~ 5.5 V
26	VSYS3V2	LDO output 3.2 V
27	VDD12	LDO output 1.2 V; Connected to 1uF Decoupling cap
28	GPIO4(VADC)	GPIO4 or ADC input
29	GPIO11	GPIO 11
30	GPIO10	GPIO 10
31	GPIO19(JTMS)	GPIO 19
32	GPIO18(JTCK)	GPIO 18
33	GPIO21(JTDO)	GPIO 21
34	GPIO20(JTDI)	GPIO 20
35	GPIO17	GPIO 17
36	GPIO16	GPIO 16
37	GPIO15	GPIO 15
38	GPIO14	GPIO 14
39	GPIO13	GPIO 13
40	GPIO12	GPIO 12
41	GPIO6	GPIO 6
42	VCC2V4	2.4 V LDO output
43	VCC3XTAL	XTAL power supply, local 1uF decoupling cap
44	XO	XTAL output
45	XI	XTAL input
46	VCCBT	Bluetooth power supply, local 1uF decoupling cap
47	GPIO5	GPIO 5
48	GPIO1	GPIO 1

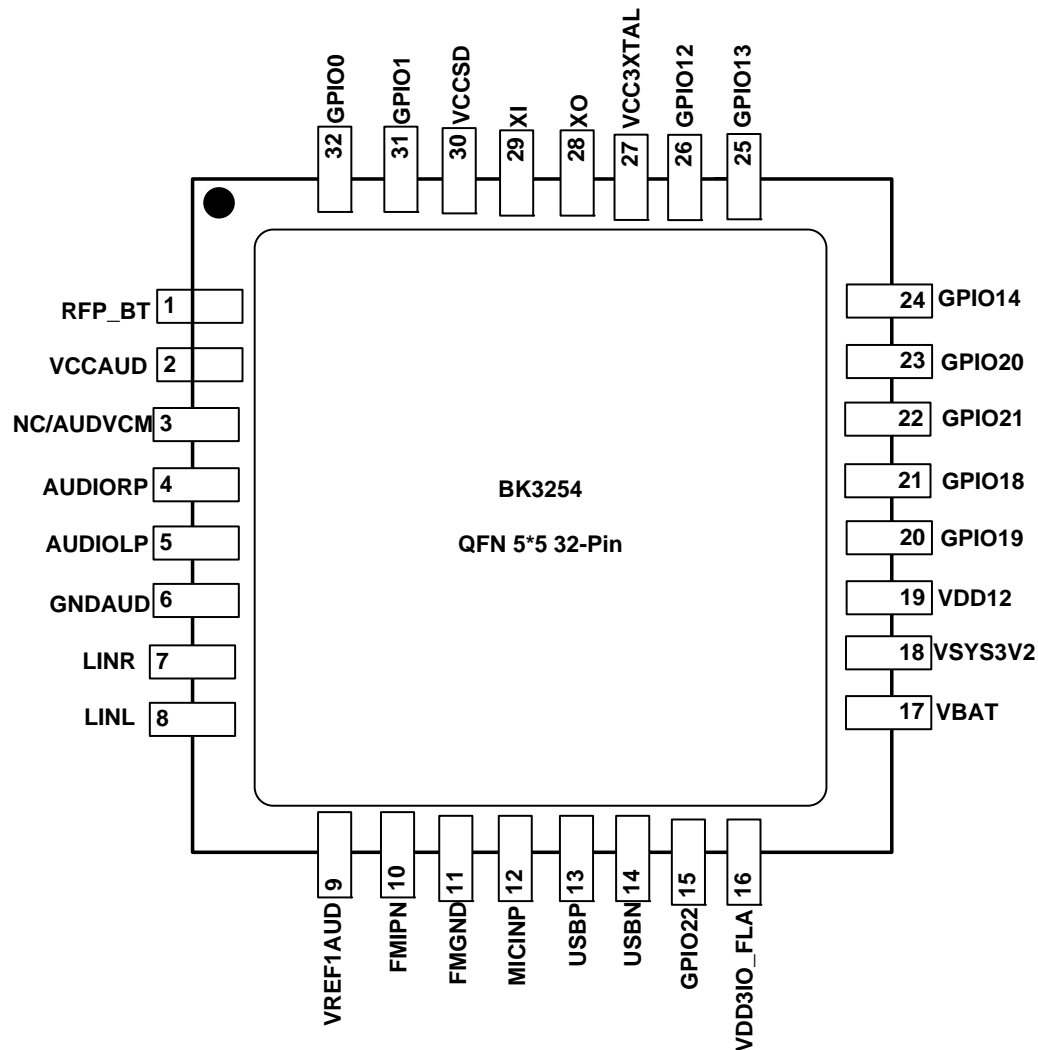

Table below has a pin description of the QFN 5x5 32-pin package

Package Pin #	Name	Description
1	RFP_BT	Bluetooth RF Input and Output
2	VCCAUD	Audio power supply; Local 1uF decoupling cap
3	NC/AUDVCM	NC. As AUDVCM only in BK3254E
4	AUDIORP	Audio output right channel
5	AUDIOLP	Audio output left channel
6	GNDAUD	GND of AUD
7	LINR	Line input right channel
8	LINL	Line input left channel



BK3254 Datasheet

v 0.5

9	VREF1AUD	Audio reference; Connected to 4.7uF decoupling cap for high audio quality
10	FMINP	FM input positive
11	FMGND	GND of FM
12	MICINP	Microphone input positive
13	USBP(GPIO2)	USB positive or GPIO 2
14	USBN(GPIO3)	USB negative or GPIO 3
15	GPIO22	GPIO 22
16	VDD3IO_FL A	LDO output for FLASH, 3 V by default, local 1uF decoupling cap
17	VCC4BAT	Battery power input, 2.8 V ~ 5.5 V
18	VSYS3V2	LDO output 3.2 V
19	VDD12	LDO output 1.2 V; Connected to 1uF Decoupling cap
20	GPIO19(JTMS)	GPIO 19
21	GPIO18(JTCK)	GPIO 18
22	GPIO21(JTDO)	GPIO 21
23	GPIO20(JTDI)	GPIO 20
24	GPIO14	GPIO 14
25	GPIO13	GPIO 13
26	GPIO12	GPIO 12
27	VCC3XTAL	XTAL power supply, local 1uF decoupling cap
28	XO	XTAL output
29	XI	XTAL input
30	VCCSD	LDO Output 2.9V; Local 1uF Decoupling cap
31	GPIO1	GPIO 1
32	GPIO0	GPIO 0



3. Functional Description

3.1. GPIO

The BK3254 has total 22 GPIOs, which can be configured as either input or output. Most of them have second function.

Table 1 GPIO Function Mapping

Name	Peripheral mode	GPIO Mode
GPIO0	UART_TXD/I2C_SCL	General I/O
GPIO1	UART_RXD/I2C_SDA	General I/O
GPIO2	TX_EN/USBP	General I/O
GPIO3	RX_EN/USBN	General I/O
GPIO4	ADC channel 1 input	General I/O
GPIO5	ADC channel 2 input	General I/O
GPIO6	SPI chip enable	General I/O
GPIO7	SPI clock or FLASH_WP	General I/O
GPIO8	SPI MOSI or FLASH_HD	General I/O
GPIO9	SPI MISO	General I/O
GPIO10	PWM0	General I/O
GPIO11	PWM1	General I/O
GPIO12	SD card clock	General I/O
GPIO13	SD card command	General I/O
GPIO14	SD card data (1-wire) or data bit 0 (4-wires)	General I/O
GPIO15	SD card data bit 1	General I/O
GPIO16	SD card data bit 2	General I/O
GPIO17	SD card data bit 3	General I/O
GPIO18	JTAG TCK	General I/O
GPIO19	JTAG TMS or ADC channel 3 input	General I/O
GPIO20	JTAG TDI	General I/O
GPIO21	JTAG TDO	General I/O
GPIO22	IrDA signal input	General I/O

All GPIO can be source to wake up MCU from shut down state. In shut down state, any level change on the set GPIO will trigger the wake up procedure.

After power on, the GPIO0~GPIO6, GPIO9~GPIO17, and GPIO22 are non-in/out with pull-low; GPIO7,GPIO8 is in second function mode; the GPIO18 to GPIO21 is JTAG mode.



3.2. PWM Timer and Watch Dog Timer

There are two sets of PWM timers. One fast set uses 1 MHz clock as main clock, and another slow set uses 32 kHz clock as main clock. Each set has three 16 bits counter with 4 bit pre-divider. First two timers in slow set can be used to LED duty cycle control.

The watch dog timer runs with 32 kHz clock, with period from 0.6 ms to 38 second.

3.3. Power Management

The BK3254 can work with power supply from 2.8 V to 5.5 V, that it can work directly with USB power supply.

The BK3254 can enter into shut down mode when there is no active connection. The shut mode can be waked up by any GPIO.

3.4. MCU

The 16 bit RISC MCU has Cache and DMA bus, to support efficient execution and frequently data exchange. The JTAG interface can be used to on-line debug, which can be also configured as GPIO.

Besides 26 MHz crystal, the MCU can run with internal DPLL clock, or 32 kHz ring oscillator clock, with programmable divided ratio.

3.5. I2C and UART Interface

There is one set of I2C interface and one set of UART interface for debug or external MCU control the BK3254.

3.6. FLASH Access Interface

The BK3254 MCU is running with the external FLASH program memory and the internal instruction cache. The external FLASH can be also used to store user data such as key configuration and Bluetooth pairing information.

3.7. SPI

The 4-wires SPI supports high speed data communication, which can be used as interface to either external FLASH or LCD controller.



3.8. SAR ADC and LED

The SAR ADC has 10-bit resolution, and the two LED drivers support up to 10 mA current.

3.9. Audio Peripheral

There are one set of speech ADC with sample rate 8 kHz or 16 kHz. The DAC have two channels for stereo application, with sample rate 8 kHz, 16 kHz, 44.1 kHz or 48 kHz.

There is also a stereo line in interface, to allow external stereo input passing internal 31 dB programmable gains amplify to stereo output.

3.10. USB

It supports USB 2.0 full speed, both host mode and device mode.

3.11. Bluetooth and FM

It supports Bluetooth 2.1+EDR A2DP/AVRCP and HPF function. The FM receiver supports 76~108 MHz stereo FM broadcasting.

4. Electrical Characteristics

4.1. Absolute Maximum Ratings

Parameter	Description	MIN	TYP	MAX	Unit
VCCBAT	Battery regulator Supply voltage	-0.3	3.3	5.5	V
P _{RX}	RX input power	-	10	-	dBm
T _{STR}	Storage temperature range	-40	-	150	°C
VCCIO	IO interface voltage	-0.3	2.8	4.2	V

4.2. Recommended Operating Conditions

Parameter	Description	MIN	TYP	MAX	Unit
VCCBAT	Battery regulator Supply voltage	2.8	4.2	5.5	V
T _{OPR}	Operation temperature range	-20	-	80	°C
VCCIO	IO interface voltage	1.8	-	3.6	V



4.3. Typical Power Consumption

State	Description	MIN	TYP	MAX	Unit
Shut down	Software shut down, wake up from GPIO		30		uA
Bluetooth Idle-Sniff	Idle state at Sniff mode		3		mA
Active (A2DP)	3DH1		45		mA
Active (HFP)	HV1		50		mA

4.4. Bluetooth Characteristics

Parameter	Condition	MIN	TYP	MAX	Unit
Operate Frequency	2402~2480	2402		2480	MHz
RXSENS-1 Mbps	BER=0.001		-90		dBm
RXSENS-2 Mbps	BER=0.0001		-92		dBm
RXSENS-3 Mbps	BER=0.0001		-84		dBm
Maximum received signal	BER=0.001	0			dBm
Maximum RF transmit power			5		dBm
RF Power Control Range		30			dB

4.5. Audio Characteristics

Parameter	Condition	MIN	TYP	MAX	Unit
DAC Output Amplitude	Single-end Output			1	Vrms
DAC Dynamic Range	1 kHz sine wave		90		dB
DAC Noise Floor	@600ohm loading		-89		dBm
DAC SNDR	Single-end@1.0Vrms		75		dB
DAC Sample Rate		8		48	kHz
ADC SNR	1 kHz sine wave		96		dB
ADC Sample Rate		8		16	kHz

5. Application Schematic

It will be provided with separate document.

6. About the Qualification

By carefully PCB layout, the BK3254 RF performance meets FCC, CE and BQB requirement. The Bluetooth protocol and profile provided by Beken are already qualified and listed in SIG website. If there is any end product listing requirement with the BK3254, please inquire Beken for the related QDID authorization.

7. Package Information

7.1. QFN48

The BK3254 package type can be QFN 6x6 48-Pin.

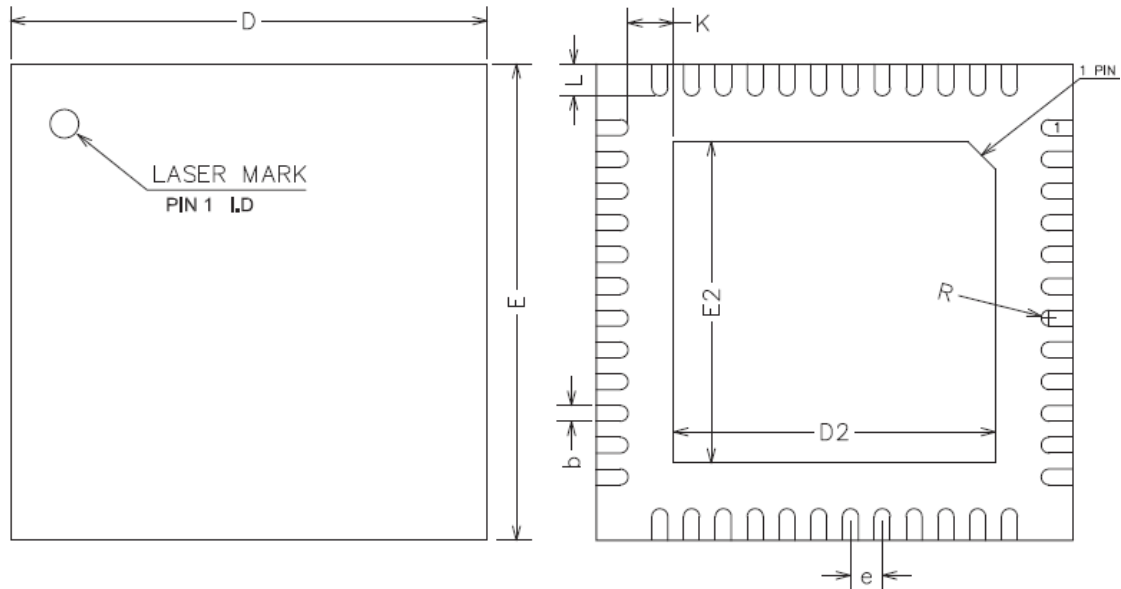

COMMON DIMENSIONS
(UNITS OF MEASURE=MILLIMETER)

SYMBOL	MIN	NOM	MAX
A	0.70	0.75	0.80
A1	0	0.02	0.05
A3	0.20REF		
b	0.15	0.20	0.25
D	5.90	6.00	6.10
E	5.90	6.00	6.10
D2	3.95	4.05	4.15
E2	3.95	4.05	4.15
e	0.35	0.40	0.45
K	0.20	-	-
L	0.35	0.40	0.45
R	0.09	-	-

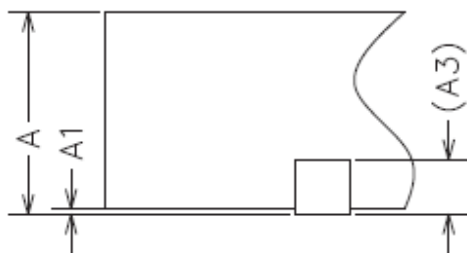

7.2. SSOP24

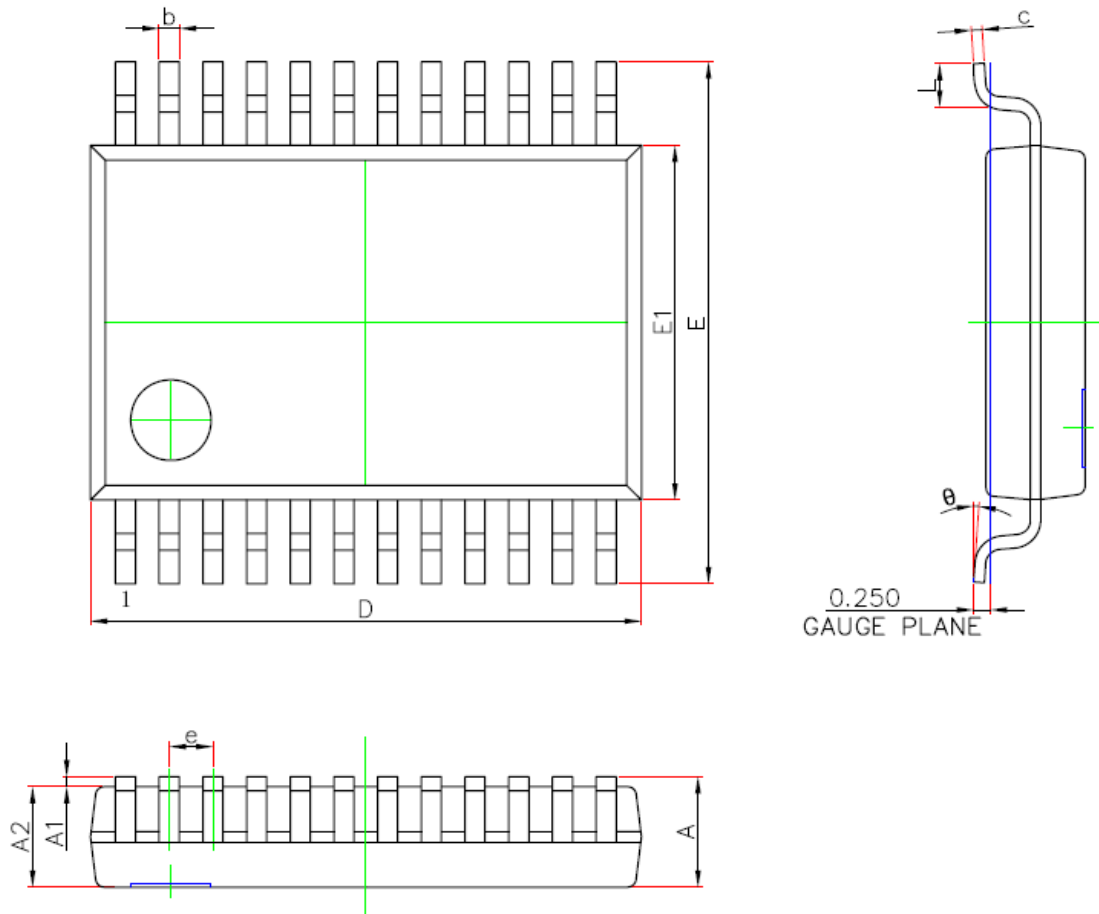

Symbol	Dimensions In Millimeters		Dimensions In Inches	
	Min.	Max.	Min.	Max.
A	—	1.850	—	0.073
A1	0.050	—	0.002	—
A2	1.400	1.600	0.055	0.063
b	0.220	0.380	0.009	0.015
c	0.090	0.250	0.004	0.010
D	7.900	8.500	0.311	0.335
E1	5.000	5.600	0.197	0.220
E	7.400	8.200	0.291	0.323
e	0.650(BSC)		0.026(BSC)	
L	0.550	0.950	0.022	0.037
θ	0°	8°	0°	8°

7.3. SSOP28

The BK3254 package type can be SSOP 28-Pin.

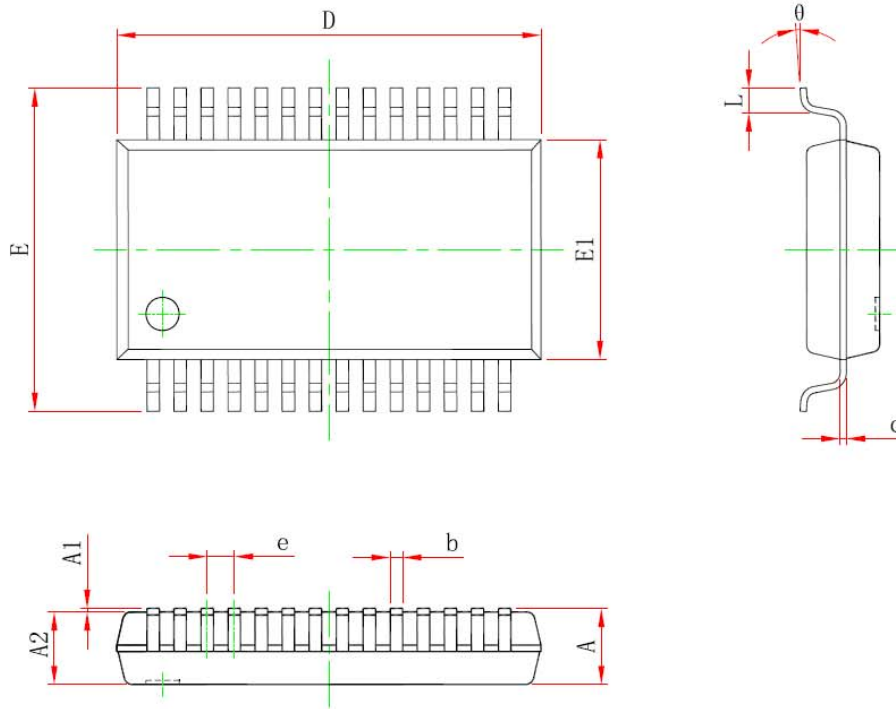

Symbol	Dimensions In Millimeters		Dimensions In Inches	
	Min	Max	Min	Max
A	--	2.000	--	0.079
A1	0.050	--	0.002	--
A2	1.650	1.850	0.065	0.073
b	0.220	0.380	0.009	0.015
c	0.090	0.250	0.004	0.010
D	9.900	10.500	0.390	0.413
E	7.400	8.200	0.291	0.323
E1	5.000	5.600	0.197	0.220
e	0.650 (BSC)		0.026 (BSC)	
L	0.550	0.950	0.022	0.037
θ	0°	8°	0°	8°

**8. Ordering Information**

Part number	Package	Packing	MOQ (ea)
BK3254QN48	QFN 6x6 48-Pin	Tape Reel	10 k
BK3254SS24	SSOP 24-Pin	Tape Reel	10 k
BK3254SS28	SSOP 28-Pin	Tape Reel	10 k

Remark:

MOQ: Minimum Order Quantity