

5A Low Dropout Positive Adjustable or Fixed-Mode Regulator

■ Features

- 1.4V maximum dropout at full load current
- Built-in thermal shutdown
- Output current limiting
- Adjustable output voltage or fixed 1.5V, 1.8V, 2.5V, 3.3V, 5.0V
- Fast transient response
- Good noise rejection
- Package : TO252, TO263, TO220

■ General Description

AP1084 is a low dropout positive adjustable or fixed-mode regulator with minimum of 5.0A output current capability. The product is specifically designed to provide well-regulated supply for low voltage IC applications such as high-speed bus termination and low current 3.3V logic supply. AP1084 is also well suited for other applications such as VGA cards. AP1084 is guaranteed to have lower than 1.4V dropout at full load current making it ideal to provide well-regulated outputs of 1.25 to 3.3V with 4.7 to 12V input supply.

■ Ordering Information

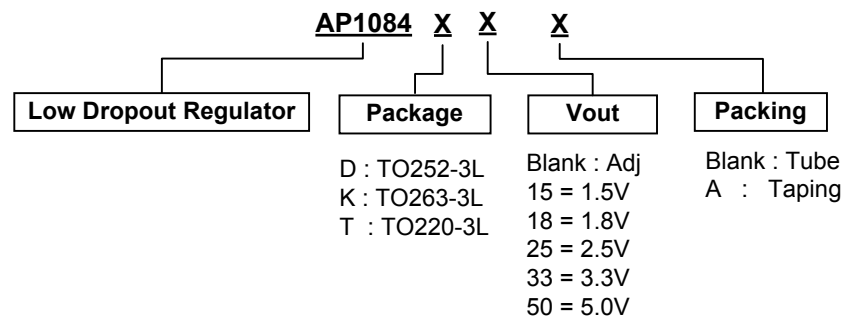

■ Typical Circuit

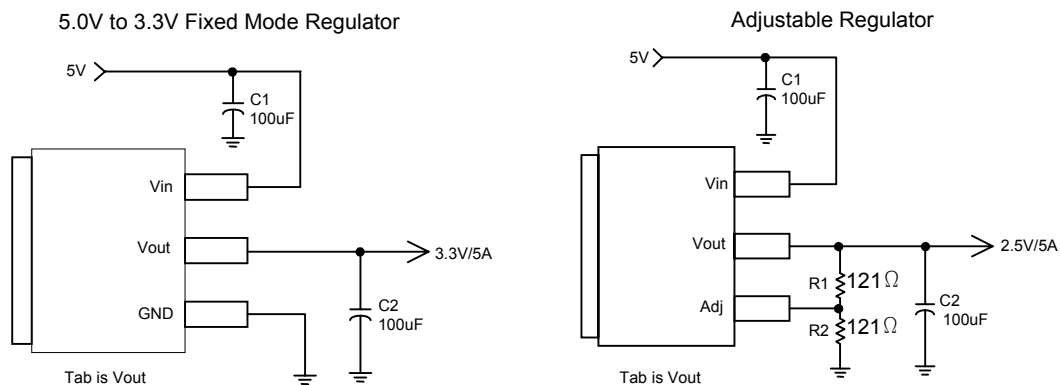

5A Low Dropout Positive Adjustable or Fixed-Mode Regulator

■ Block Diagram

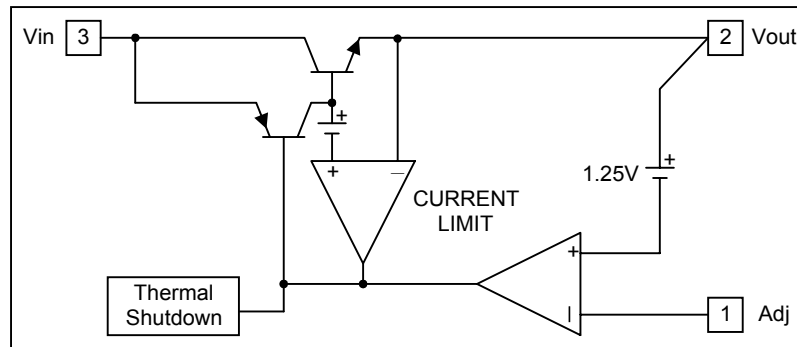

■ Connection Diagram

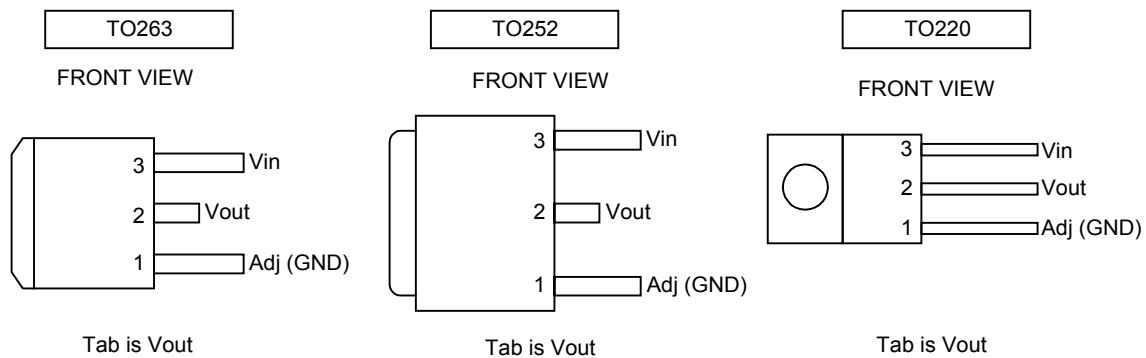

■ Pin Descriptions

NAME	I/O	PIN #	FUNCTION
Adj (GND)		1	Adjustable (Ground only for fixed mode)
Vout	O	2	The output of the regulator. A minimum of 10uF capacitor must be connected from this pin to ground to insure stability.
Vin	I	3	The input pin of regulator. Typically a large storage capacitor is connected from this pin to ground to insure that the input voltage does not sag below the minimum dropout voltage during the load transient response. This pin must always be 1.4V higher than Vout in order for the device to regulate properly.



5A Low Dropout Positive Adjustable or Fixed-Mode Regulator

■ Absolute Maximum Ratings

Symbol	Parameter	Rating	Unit
V _{in}	DC Supply Voltage	-0.3 to 12	V
P _D	Power Dissipation	Internally Limited	
T _{ST}	Storage Temperature	-65 to +150	°C
T _{OP}	Operating Junction Temperature Range	0 to +150	°C

■ Electrical Characteristics (Under Operating Conditions)

SYM.	PARAMETER	CONDITIONS (Notes)	MIN	TYP	MAX	UNIT
V _{REF}	Reference Voltage	I _o =10mA, T _j =25°C, (V _{in} -V _{out})=1.5V	1.225	1.250	1.275	V
Line Regulation	AP1084-XXX	I _o =10mA, V _{OUT} +1.5V<V _{IN} <12V, T _J =25°C			0.2	%
	AP1084-1.5	I _{OUT} = 10mA, T _J = 25°C, 3V ≤ V _{IN} ≤ 12V	1.470	1.500	1.530	V
	AP1084-1.8	I _{OUT} = 10mA, T _J = 25°C, 3.3V ≤ V _{IN} ≤ 12V	1.764	1.800	1.836	V
	AP1084-2.5	I _{OUT} = 10mA, T _J = 25°C, 4V ≤ V _{IN} ≤ 12V	2.450	2.500	2.550	V
	AP1084-3.3	I _{OUT} = 10mA, T _J = 25°C, 4.8V ≤ V _{IN} ≤ 12V	3.235	3.300	3.365	V
	AP1084-5.0	I _{OUT} = 10mA, T _J = 25°C, 6.5V ≤ V _{IN} ≤ 12V	4.900	5.000	5.100	V
Load Regulation	AP1084-Adj	V _{IN} =3.3V, 0mA<I _o <5A, T _J =25°C (Note 1,2)			1	%
	AP1084-1.5	V _{IN} =3V, 0mA<I _o <5A, T _J =25°C (Note 1,2)		12	15	mV
	AP1084-1.8	V _{IN} =3.3V, 0mA<I _o <5A, T _J =25°C (Note 1,2)		15	18	mV
	AP1084-2.5	V _{IN} =4V, 0mA<I _o <5A, T _J =25°C (Note 1,2)		20	25	mV
	AP1084-3.3	V _{IN} = 5V, 0mA<I _o <5A, T _J =25°C (Note 1,2)		26	33	mV
	AP1084-5.0	V _{IN} = 8V, 0mA<I _o <5A, T _J =25°C (Note 1,2)		40	50	mV
ΔV _o	Dropout Voltage	I _o =5.0A (ΔV _{out} = 1% V _{out})		1.3	1.4	V
	Current Limit	V _{in} -V _{out} =5V	5.1			A
	Minimum Load Current			5	10	mA

5A Low Dropout Positive Adjustable or Fixed-Mode Regulator

	Temperature Stability	Io=10mA		0.5		%
θ_{JA}	Thermal Resistance Junction-to-Ambient (No heat sink ;No air flow)	TO-252 TO-263 TO-220		98 91 83		$^{\circ}\text{C/W}$
θ_{JC}	Thermal Resistance Junction-to-Case	TO-252: Control Circuitry/Power Transistor TO-263: Control Circuitry/Power Transistor TO-220: Control Circuitry/Power Transistor		15 10 0.65/2.7		$^{\circ}\text{C/W}$

Note 1: See thermal regulation specifications for changes in output voltage due to heating effects. Line and load regulation are measured at a constant junction temperature by low duty cycle pulse testing. Load regulation is measured at the output lead = 1/18" from the package.

Note 2: Line and load regulation are guaranteed up to the maximum power dissipation of 15W. Power dissipation is determined by the difference between input and output and the output current. Guaranteed maximum power dissipation will not be available over the full input/output range.

■ Functional Description

Introduction

The AP1084 adjustable Low Dropout (LDO) regulator is a 3 terminal device that can easily be programmed with the addition of two external resistors to any voltages within the range of 1.25 to 5V. The AP1084 only needs 1.4V differential between V_{in} and V_{out} to maintain output regulation. In addition, the output voltage tolerances are also extremely tight and they include the transient response as part of the specification. For example, Intel VRE specification calls for a total of +/- 100mV including initial tolerance, load regulation and 0 to 5.0A load step.

The AP1084 is specifically designed to meet the fast current transient needs as well as providing an accurate initial voltage, reducing the overall system cost with the need for fewer output capacitors.

Output Voltage Setting

The AP1084 can be programmed to any voltages in the range of 1.25V to 5V with the addition of R1 and R2 external resistors according to the following formula:

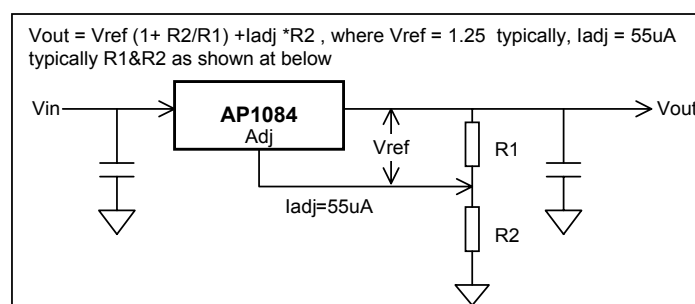

The AP1084 keeps a constant 1.25V between the output pin and the adjust pin. By placing a resistor R1 across these two pins a constant current flows through R1, adding to the I_{adj} current and into the R2 resistor producing a voltage equal to the $(1.25/R1)*R2 + I_{adj}*R2$ which will be added to the 1.25V to set the output voltage. This is summarized in the above equation. Since the minimum load current requirement of the AP1084 is 10mA, R1 is typically selected to be 121 Ω resistor so that it automatically satisfies the minimum current requirement. Notice that since I_{adj} is typically in the range of 55uA it only adds a small error to the output voltage and should only be considered when a very precise output voltage setting is required. For example, in a typical 3.3V application where R1=121 Ω and R2=200 Ω the error due to I_{adj} is only 0.3% of the nominal set point.



ATC

AP1084

5A Low Dropout Positive Adjustable or Fixed-Mode Regulator

Load Regulation

Since the AP1084 is only a 3 terminal device, it is not possible to provide true remote sensing of the output voltage at the load. The best load regulation is achieved when the bottom side of R2 is connected to the load and the top-side of R1 resistor is connected directly to the case or the Vout pin of the regulator and not to the load. It is important to note that for high current applications, this can re-present a significant percentage of the overall load regulation and one must keep the path from the regulator to the load as short as possible to minimize this effect.

Stability

The AP1084 requires the use of an output capacitor as part of the frequency compensation in order to make the regulator stable. For most applications a minimum of 10uF aluminum electrolytic capacitor insures both stability and good transient response.

Thermal Design

The AP1084 incorporates an internal thermal shutdown that protects the device when the junction temperature exceeds the maximum allowable junction temperature. Although this device can operate with junction temperatures in the range of **150°C**, it is recommended that the selected heat sink be chosen such that during maximum continuous load operation the junction temperature is kept below the temperature.

Layout Consideration

The output capacitors must be located as close to the Vout terminal of the device as possible. It is recommended to use a section of a layer of the PC board as a plane to connect the Vout pin to the output capacitors to prevent any high frequency oscillation that may result due to excessive trace inductance.

5A Low Dropout Positive Adjustable or Fixed-Mode Regulator

■ Performance Characteristics

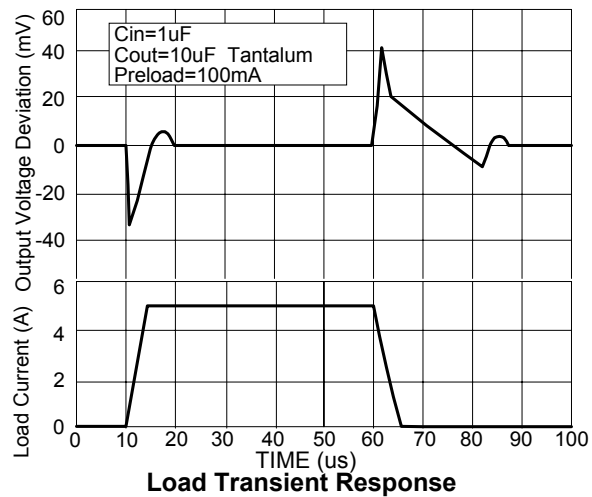
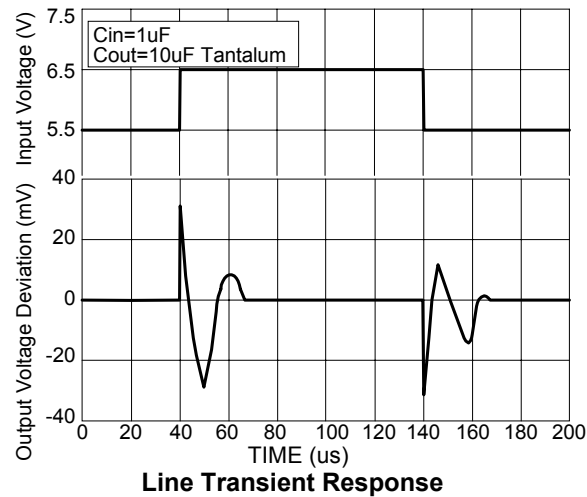
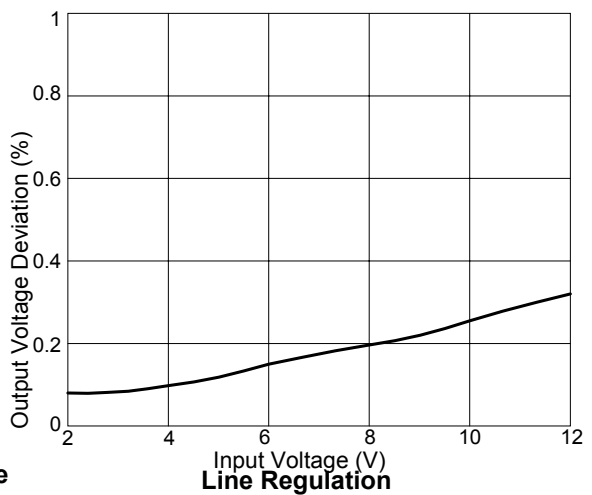
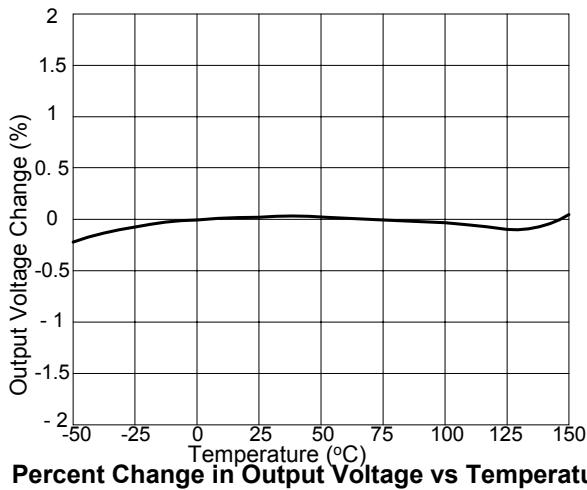
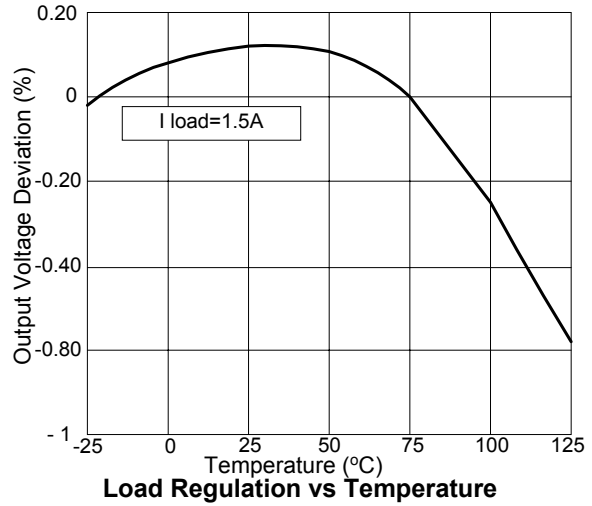
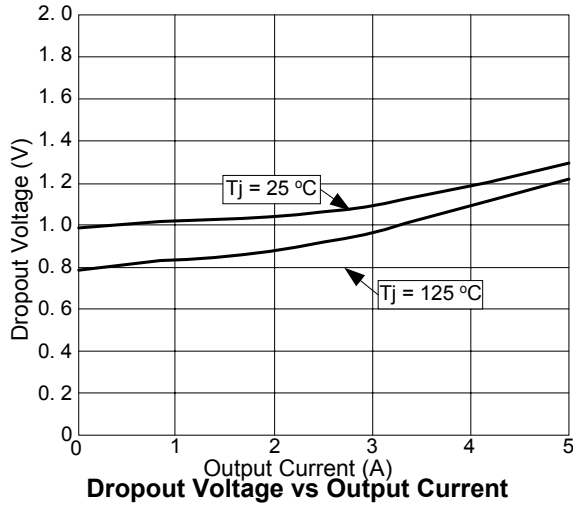

5A Low Dropout Positive Adjustable or Fixed-Mode Regulator

■ Marking Information

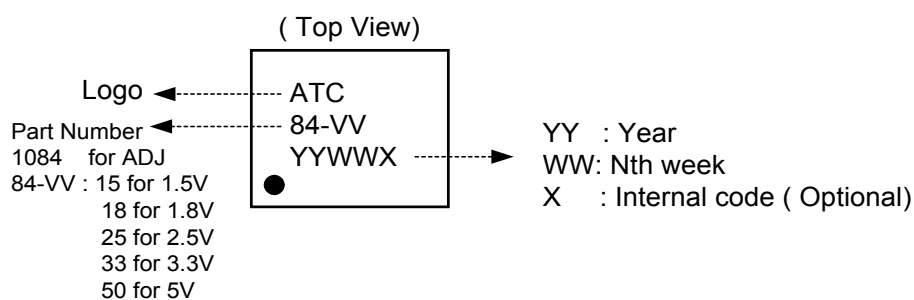

(TO252-3L)

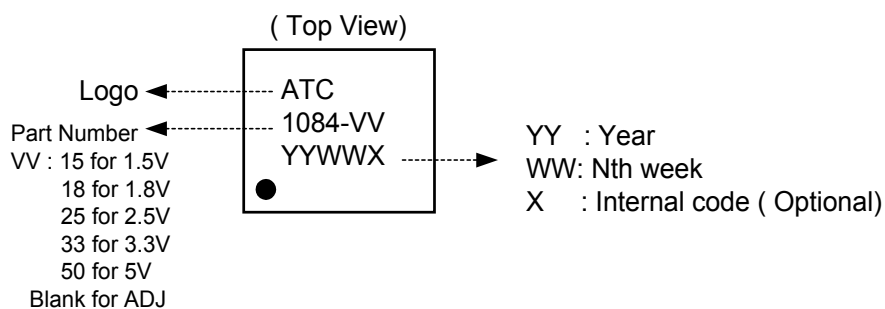

(TO220-3L / TO263-3L)

5A Low Dropout Positive Adjustable or Fixed-Mode Regulator

■ Package Dimension

(1) TO263-3L

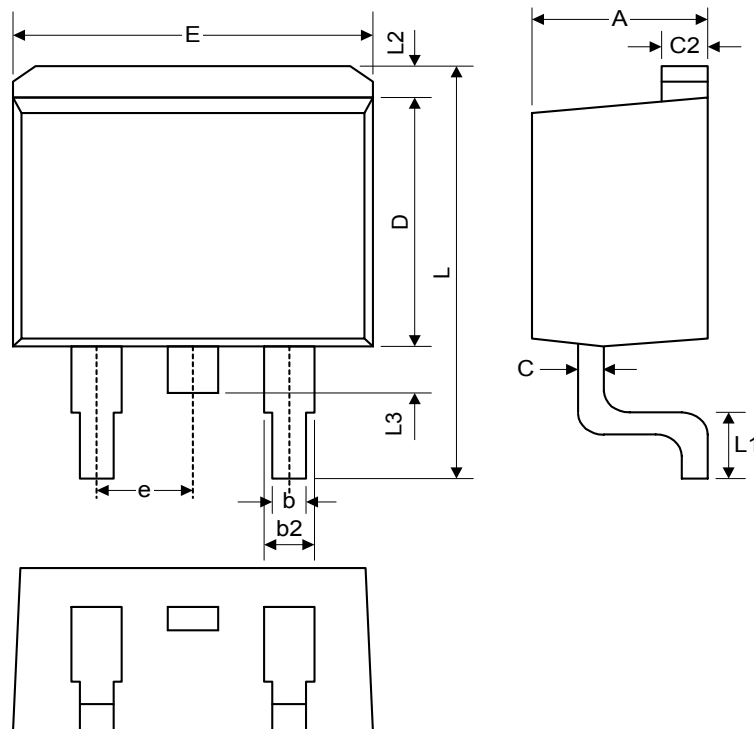

Symbol	Dimensions In Millimeters			Dimensions In Inches		
	Min.	Nom.	Max.	Min.	Nom.	Max.
A	4.06	4.45	4.83	0.160	0.175	0.190
b	0.51	0.75	0.99	0.020	0.030	0.039
b2	1.14	1.27	1.40	0.045	0.050	0.055
C	3.81 TYP.			0.015 TYP.		
C2	1.14	1.27	1.40	0.045	0.050	0.055
D	8.65	9.15	9.65	0.341	0.360	0.380
E	9.65	9.97	10.29	0.380	0.393	0.405
e	2.54 BSC.			0.100 BSC.		
L	14.61	15.24	15.88	0.575	0.600	0.625
L1	2.28	2.54	2.80	0.090	0.100	0.110
L2	-	-	2.92	-	-	0.115
L3	1.27	1.52	1.78	0.050	0.060	0.070

5A Low Dropout Positive Adjustable or Fixed-Mode Regulator

(2) TO252-3L

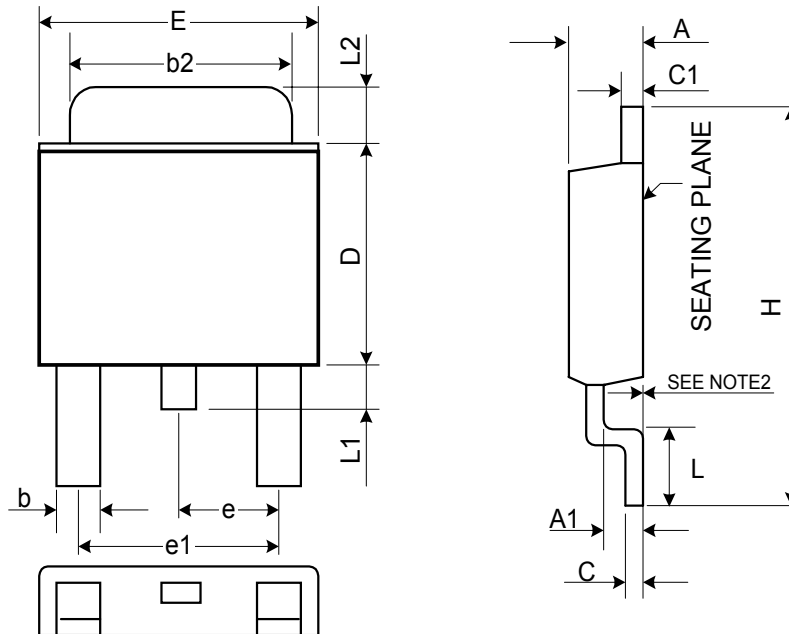

Notes:

1. JEDEC Outline: TO-252 AB
2. Mils suggested for positive contact at mounting.

Symbol	Dimensions In Millimeters			Dimensions In Inches		
	Min.	Nom.	Max.	Min.	Nom.	Max.
A	2.18	2.29	2.39	0.086	0.090	0.094
A1	1.02	1.15	1.27	0.040	0.045	0.050
b	0.61 TYP.			0.024 TYP.		
b2	5.20	5.35	5.50	0.205	0.211	0.217
C	0.46	0.52	0.58	0.018	0.020	0.023
C1	0.46	0.52	0.58	0.018	0.020	0.023
D	5.33	5.57	5.80	0.210	0.219	0.228
E	6.35	6.58	6.80	0.250	0.259	0.268
e	2.25 BSC.			0.089 BSC.		
e1	4.50 BSC.			0.177 BSC.		
H	9.00	9.70	10.40	0.354	0.382	0.409
L	0.51	-	-	0.020	-	-
L1	0.64	0.83	1.02	0.025	0.033	0.040
L2	1.52	1.78	2.03	0.060	0.070	0.080

5A Low Dropout Positive Adjustable or Fixed-Mode Regulator

(3) TO220-3L

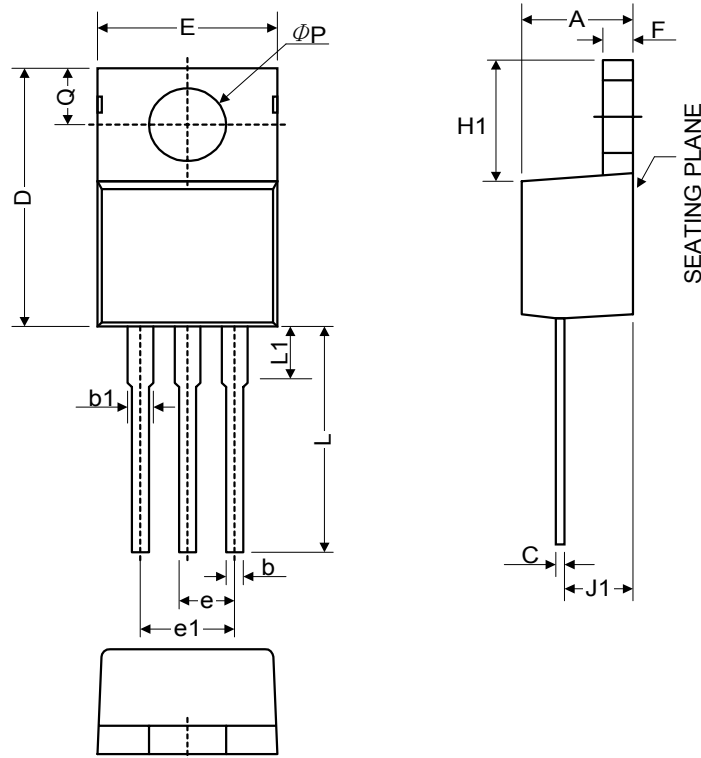

Symbol	Dimensions In Millimeters			Dimensions In Inches		
	Min.	Nom.	Max.	Min.	Nom.	Max.
A	3.55	4.20	4.85	0.140	0.165	0.191
b1	1.14	1.46	1.78	0.045	0.057	0.070
b	0.51	0.83	1.14	0.020	0.033	0.045
C	0.31	0.72	1.14	0.012	0.028	0.045
D	14.20	15.35	16.50	0.559	0.604	0.650
E	9.70	10.20	10.70	0.382	0.402	0.421
e	2.29	2.54	2.79	0.090	0.100	0.110
e1	4.83	5.08	5.33	0.190	0.200	0.210
F	0.51	0.95	1.40	0.020	0.037	0.055
H1	5.84	6.35	6.86	0.230	0.250	0.270
J1	2.03	2.48	2.92	0.080	0.098	0.115
L	12.72	13.72	14.72	0.501	0.540	0.580
L1	3.66	5.00	6.35	0.144	0.197	0.250
ϕP	3.53	3.81	4.09	0.139	0.150	0.161
Q	2.54	2.98	3.43	0.100	0.117	0.135