

Part: HL-304H3GC



ATTENTION
OBSERVE PRECAUTIONS
FOR HANDLING
ELECTROSTATIC
DISCHARGE
SENSITIVE
DEVICES



Features:

- φ3 LAMP LED
- LOW POWER CONSUMPTION.
- CABINED VIEWING ANGLE.
- IDEAL FOR BACKLIGHT AND INDICATOR.
- PACKAGE: 1000PCS / BAG.

Description:

This devices are made with TS GaP.

Package Dimensions:

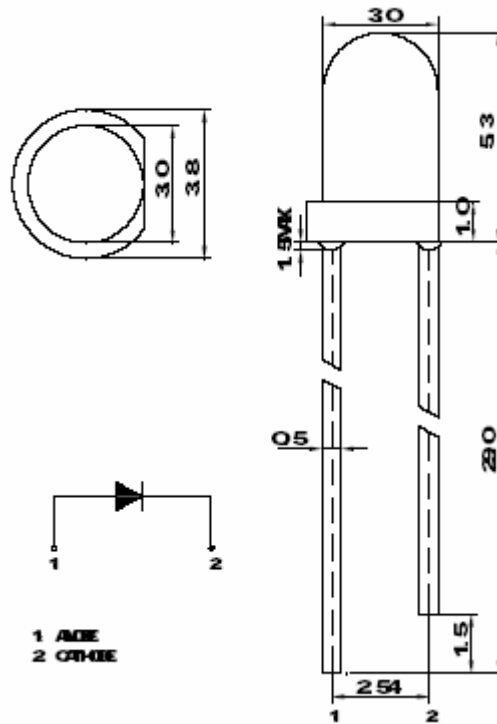

| Tolerance Grade | Dimension Tolerance (UNIT:mm) | | | |
|-----------------|-------------------------------|-------------------|------|--------|
| | 0.5~3 | 3~6 | 6~30 | 30~120 |
| Medium (m) | ±0.1 | ±0.2 | ±0.3 | ±0.5 |
| Chip | | Lens Color | | |
| Material | Emitting Color | Water Clear | | |
| GaP | Greenish | | | |

| | | |
|--|--------|--|
| | Yellow | |
|--|--------|--|

■ Absolute Maximum Rating

| Item | Symbol | Absolute Maximum Rating | Unit |
|-----------------------------|--------|--------------------------|------|
| Forward Current | IF | 20 | mA |
| Peak Forward Current* | IFP | 100 | mA |
| Reverse Voltage | VR | 5 | V |
| Power Dissipation | PD | 80 | mW |
| Electrostatic discharge | ESD | 2000 | V |
| Operation Temperature | Topr | -30~+80 | °C |
| Storage Temperature | Tstg | -30~+80 | °C |
| Lead Soldering Temperature* | Tsol | Max. 260°C for 5sec Max. | |

* IFP Conditions: Pulse Width≤10msec

* Tsol Conditions: 3mm from the base of the epoxy bulb

■ Typical Optical/ Electrical Characteristics

| Item | Symbol | Condition | Min. | Typ. | Max. | Unit |
|---------------------------|---------|-----------|------|------|------|------|
| Forward Voltage | VF | IF=20mA | 1.8 | 2.2 | 2.6 | V |
| 50% Power Angle | 2θ 1/2 | | -- | 40 | -- | deg |
| Luminous Intensity | Iv | | 210 | -- | 276 | mcd |
| Prpc Wavelength | λD | | 565 | -- | 575 | nm |
| Recommend Forward Current | IF(rec) | -- | -- | -- | 20 | mA |
| Reverse Current | IR | Vr=5V | -- | -- | 20 | uA |

Notes:

1. Absolute maximum ratings Ta=25°C.
2. Tolerance of measurement of forward voltage±0.1V.
3. Tolerance of measurement of peak Wavelength±2.0nm.
4. Tolerance of measurement of luminous intensity±15%.
5. Tolerance of measurement of angle intensity±15%.

■ Reliability Performance Test Items And Result

| Test Classification | Test Item | Test Conditions | Test Duration | Sample Size | AC/RE |
|---------------------|---|---|---------------|-------------|-------|
| Life Test | Room Temperature DC Operating Life Test | Ta=25°C ±5°C, IF=20mA | 1000 hrs | 22 pcs | 0/1 |
| Environment Test | Thermal Shock Test | 100°C ±5°C 5min ↑↓ -40°C ±5°C 5min. | 100 cycles | 22 pcs | 0/1 |
| | Temperature Cycle Test | 100°C ±5°C 30min ↑↓5min -40°C ±5°C 30min. | 100 cycles | 22 pcs | 0/1 |
| | Temperature & Cycle Test | 85°C ±5°C /85% RH IF=5mA | 1000 hrs | 22 pcs | 0/1 |
| | Temperature Cycle Test | Ta=100°C ±5°C | 1000 hrs | 22 pcs | 0/1 |
| | Low Temperature Storage | Ta=100°C ±5°C | 1000 hrs | 22 pcs | 0/1 |
| Mechanical Test | Resistance to Soldering Heat | Ta=100°C ±5°C | 1 times | 22 pcs | 0/1 |
| | Lead Integrity | Load 2.5N(0.25kgf) 0° ~ 90° ~ 0° | 3 times | 22 pcs | 0/1 |

The technical information shown in the data sheets are limited to the typical characteristics and circuit examples of the referenced. It does not constitute the warranting of industrial property nor the granting of any license.

Forward Current vs. Ambient Temperature Relative Intensity vs. Ambient Temperature

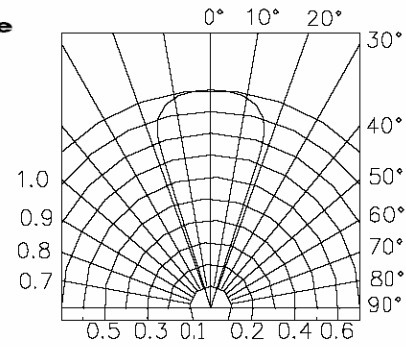
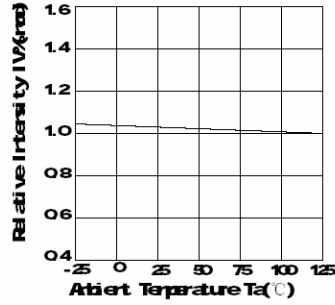
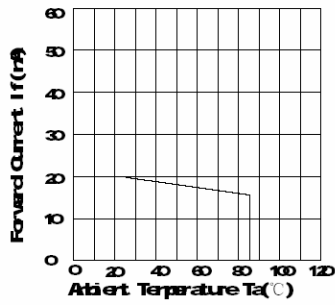

Forward Current vs. Forward Voltage Forward Voltage vs. Ambient Temperature

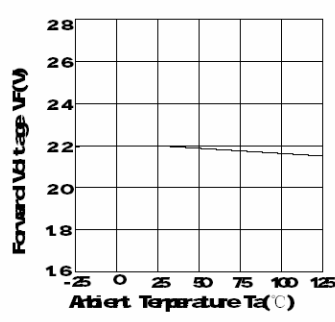
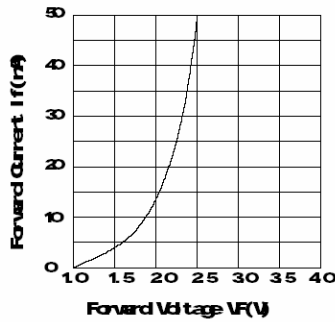

Luminous Spectrum ($T_a=25^\circ\text{C}$) SPECIAL RADIANE

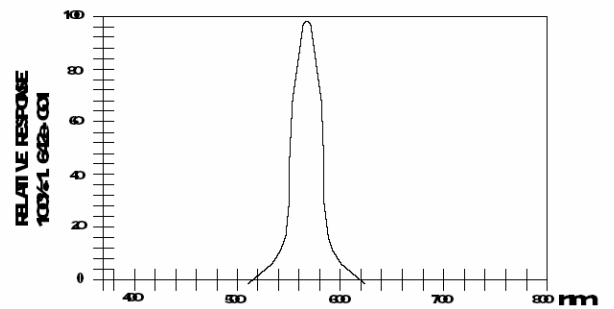

Soldering:

1. Manual Of Soldering

The temperature of the iron tip should not be higher than 260°C (500°F) and Soldering within 3 seconds per solder-land is to be observed.

2. DIP soldering (Wave Soldering):

Preheating: 120°C ~150°C, within 120~180 sec.

Operation heating: 245°C ±5°C within 5 sec. 260°C (Max)

Gradual Cooling (Avoid quenching).

