

QUARTZ CRYSTAL UNIT

Product Brief Introduction

SERIES: **HC49S & HC49SS**

Application:

Radio communication, Audio-visual equipment, Office automation equipment, Consumer product

**Specification**

Frequency range	See table 1
Vibration mode	AT cut: fundamental. Third
Frequency tolerance at 25 °C	±10, ±15, ±20, ±30, ±50 ppm
Operating temperature range and frequency stability	See Table 2
Equivalent series resistance	See Table 1
Shunt capacitance	5.0pF max or special
Measure instrument	S&A 250B PI system
Load capacitance	Series, 16, 20, 30pF or special
Drive level	10,100, 300, 500uW or special
Insulation resistance	500 M Ω min/DC 100V
Aging	±1, 3, 5ppm/ year
Storage temperature range	-40 ~ +85°C

**Table 1/ Frequency range & Equivalent Series resistance**

Frequency (MHz)	Vibration mode	HC-49S(Ω)
3.2~3.79	Fundamental /F	180
3.8~4.49	Fundamental /F	150
4.5~5.99	Fundamental /F	120
6.0~7.99	Fundamental /F	100
8.0~9.99	Fundamental /F	80
10.0~11.9	Fundamental /F	70
12.0~15.9	Fundamental /F	60
16.0~19.9	Fundamental /F	50
20.0~26.0	Fundamental /F	40
26.0~39.9	Third/ O3	100
40.0~100.0	Third/ O3	80

**Table 2/ Operating temperature range and frequency stability**

TEMP	PPM	±10	±15	±20	±30	±50
0~+50°C		☆	☆	☆	☆	☆
-10~+60°C		☆	☆	☆	☆	☆
-20~+70°C		☆	☆	☆	☆	☆
-30~+80°C				☆	☆	☆
-40~+90°C					☆	☆

The mark " ☆ " denotes our achieved level

**DIMENSIONS (mm)**

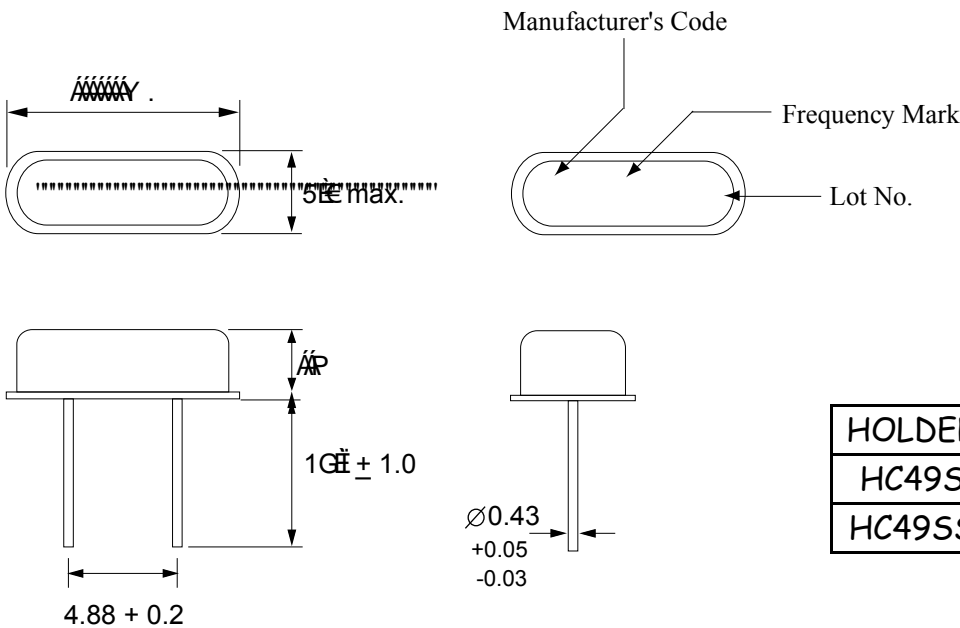

HOLDER	W	H
HC49S	11.5	3.5
HC49SS	11.5	2.5